

დიზაინი & მონტაჟი

ქერი

მოდულურ ჯერის
გათბობა გაგრილება

ModularCeiling



12/2022

PDF



www.variotherm.com

VARIOTHERM

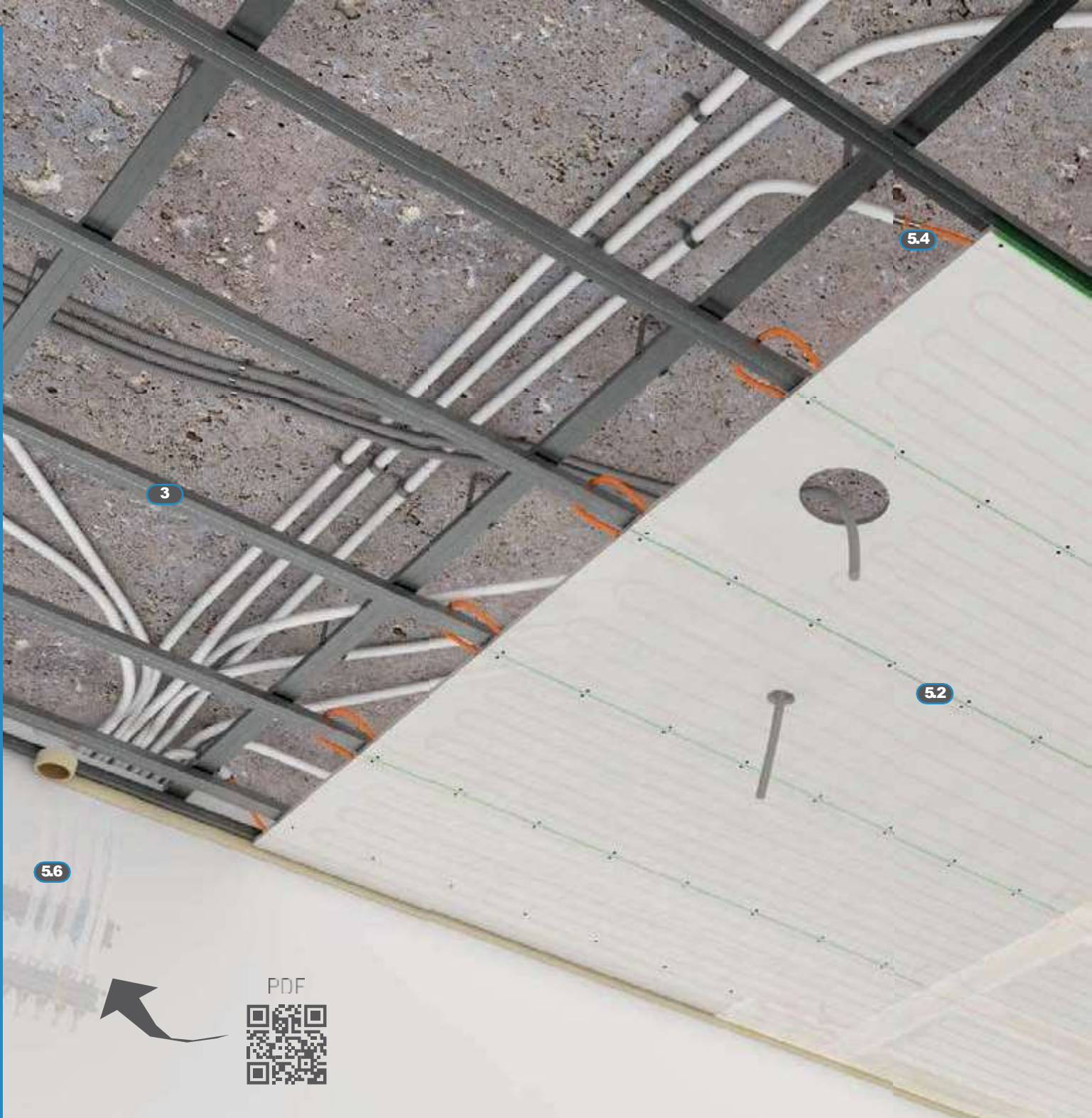

PDF



1	PRINCIPLES	4	3	SUBSTRUCTURE	10
1.1	Cooling	4	3.1	General	10
1.2	Heating	6	3.2	Spacing in the edge area	10
1.3	Energy saving	6	3.3	Basic battens/profiles (standard).....	10
1.4	Planning freedom.....	6	4.	Support battens/profiles (without basic battens)	11
1.5	Descriptive and advantages of Modular Ceiling.....	7	5.	Support battens directly attached (without basic battens)	12
2	PREPARATION	8	3.6	Movement joints	12
2.1	Warranty conditions	8	3.7	Insulation in substructure	12
2.2	Standards information.....	8	4	FIRE PROTECTION	13
2.3	Fire protection	8	5	COMPONENTS	14
2.4	Load-bearing walls.....	8	1.	ModularPanels / ModularExpansionPanels - Overview...	14
2.5	Goods transport/storage.....	8	2.	ModularPanels / ModularExpansionPanels - Installation	18
2.6	Tools.....	9	5.3	VarioModular pipes.....	24
2.7	Visible side/rear side of the ModularPanel.....	9	5.4	Press-fit couplings / press tools	25
2.8	Humidity.....	9	5.5	Dew-point monitor (on-site).....	27
2.9	Maximum flow temperature and dew point.....	9	5.6	VarioManifold.....	27
2.10	Other work documents				

This is how
it's done...



6	FINISHED SURFACE	28		
	6.1 Filling	28		
	6.2 Painting.....	28		
	6.3 Load attachment of the ModularCeiling	28		
7	ACOUSTICS	29		
8	HEATING/COOLING PRACTICE	30		
	1. Calculation of the heating and cooling load.....	30		
	8.2 Variotherm Dimensioning software	30		
	8.3 Cooling capacity and dew point.....	31		
	8.4 Heat emission.....	31		
	8.5 Pressure loss.....	32		
9	QUALITY CONTROL	34		
	1. Leak-tightness test (in accordance with EN 1264-4)	34		
	2. Functional heating (in compliance with EN 1264-4 or BVF)	35		
	9.3 Commissioning.....	35		

1 PRINCIPLES

Variotherm recommends a combination of floor, wall and ceiling.

For hot summer days, we recommend wall and/or ceiling cooling. Instead of hot water, cool water flows through the pipes at a temperature of 16-20 °C. Rooms are cooled to a comfortable temperature - without draughts and no noise whatsoever.

In general, walls offer the largest exchange area, which is why wall heating systems ensure that people can easily feel the radiant heat.

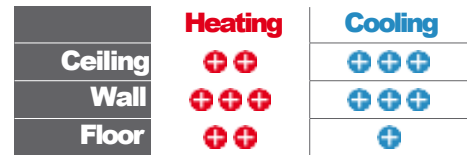

▲ Which system areas are suitable for which needs?

Heat production
heat loss

1.1 Cooling

Comfort is not only created by a specific air temperature in the room. Equally important is the temperature of all surfaces enclosing the room. The physiologically perceived temperature corresponds approximately to the arithmetic mean of the two.

When does a person feel comfortable?

A person only feels comfortable when the basic equation of "thermal comfort" is fulfilled:

$$\text{heat generation} = \text{heat emission}$$

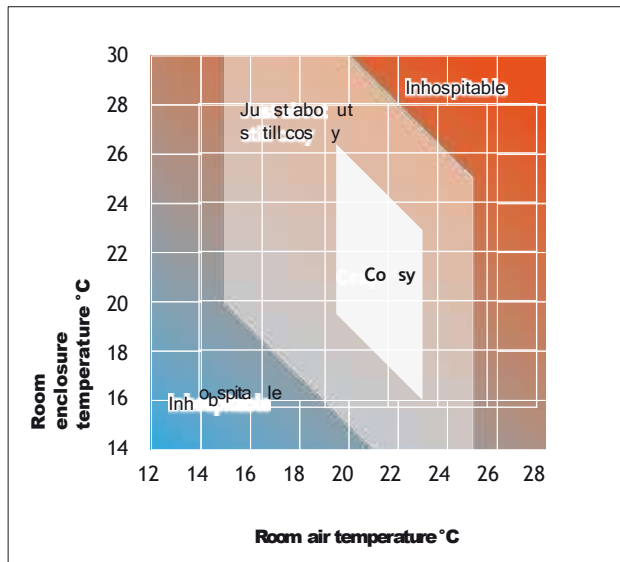

▲ Zone of cosiness

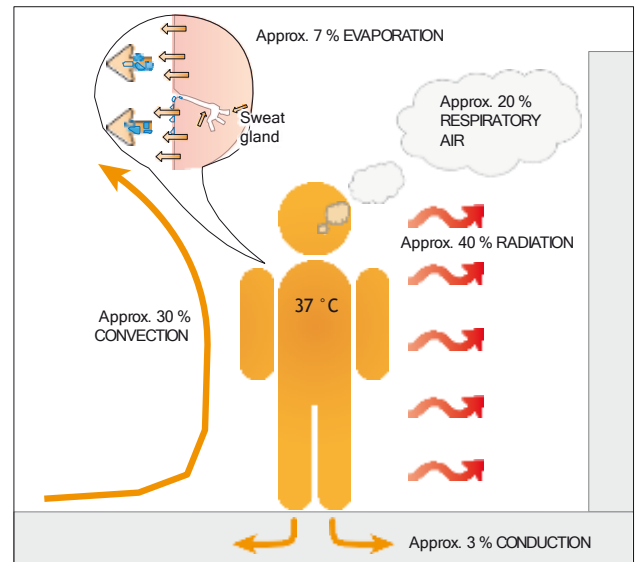

▲ Human heat balance

Cooling via ceiling surfaces offers the advantage of a gentle radiant exchange between the cooled ceiling surface and the human body, But other warmer objects in the room (floor, interior walls, furnishings, etc.) also give off heat to this cooled surface, because radiation always travels from the warmer to the colder object. This heat extraction leads to a reduction in the surface temperature of these objects and thus to a cooling effect. The room air is also reduced to a comfortable level.

The ModularCeiling generates neither unpleasant draughts nor noise, which is often perceived as annoying with conventional air conditioning systems.

Cooling as of ≥ 26 °C room air temperature has proved expedient. Lowering of the ceiling surface temperature to approx. 19-22 °C is sufficient to achieve a noticeable effect and adequate body cooling.

Economic efficiency

The required cooling capacity can be better distributed via the medium of water than via air. The pump costs incurred during operation are usually lower than the costs for ventilators. Even a 100 % coverage of the cooling load in accordance with VDI 2078 (calculation of the cooling load of air-conditioned rooms) is possible in low-energy buildings with sunshades and few internal loads.

One of the greatest advantages of ceiling cooling/ceiling heating systems are the low additional investment costs. One and the same system is used for cooling and heating: The same ceiling area, the same pipe system and the same heating/cooling manifold with supply pipes and circulation pump. Refrigeration (refrigeration machine/heat pump/cold from the ground and groundwater) is planned parallel to the heating unit. Many modern heat pumps of modern can already be switched from heating to cooling - without any great additional costs. However, ambient coldness (deep drilling, surface collectors, wells, etc.) can also be used as a cooling source - at zero cost, so to speak.

Combination of displacement ventilation and surface cooling

Where dehumidification and ventilation are concerned, surface cooling does not replace an air-conditioning system. Displacement ventilation is an air-conditioning system with low discharge velocities and laminarisation of the exiting air at the air outlets. A low-turbulence room air flow is achieved due to the way the air is conducted in the room, blowing in close to the floor with slightly

lower temperatures and extracting the exhaust air near the ceiling. This form of displacement flow, known as “displacement ventilation”, can achieve practically complete freedom from draughts. Combining a ceiling cooling and a displacement ventilation system means considerably higher cooling capacities can be achieved than would be the case with the displacement ventilation system alone, without exceeding the thermally comfortable air velocities. If the supplied air is dehumidified, low ceiling surface temperatures and thus high radiant cooling capacity can be achieved without condensation, even on humid days.

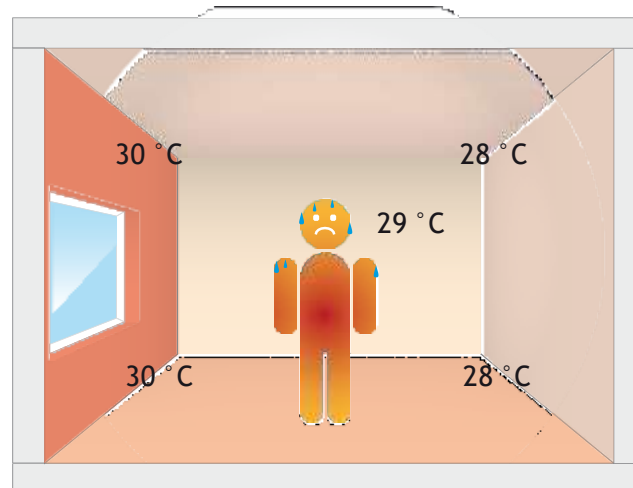

▲ Discomfort without cooling

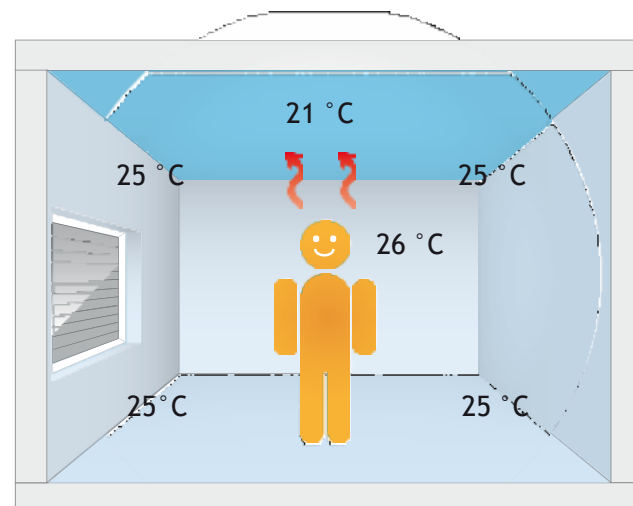

▲ Comfort with ceiling cooling

Advantages ModularCeiling

1.2 Heating

The ModularCeiling is not only suitable for cooling, but can also be used for heating. Compared to other heating systems, the feeling of comfort is significantly increased with the ModularCeiling heating systems. The room temperature can be set lower than with convection heating systems, as people perceive the temperature as higher due to the heat radiation.

It is important that the heat emitted by the human body can be emitted to all sides as evenly as possible. If too much heat is extracted (e.g. cold surfaces, draughts) from one side or if the heat transfer is obstructed on one side (hot surfaces or vapour-tight, thick clothing), we experience this as unpleasant.

The lower the air temperature in the room, the warmer the enclosing surfaces (wall surfaces, floors, ceilings, but also windows) have to be to make it cosy.

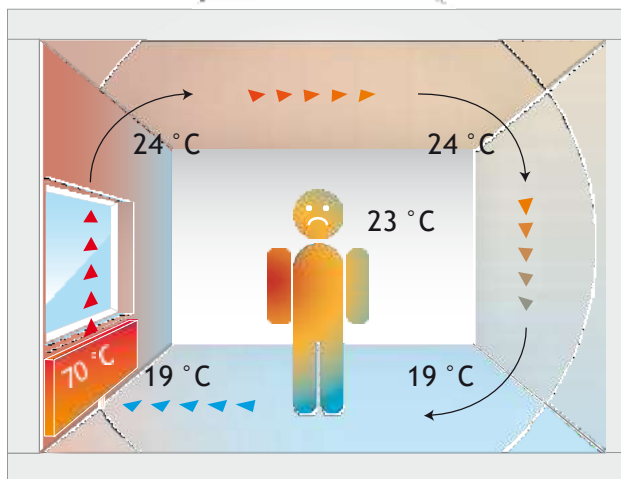

▲ Discomfort with radiators

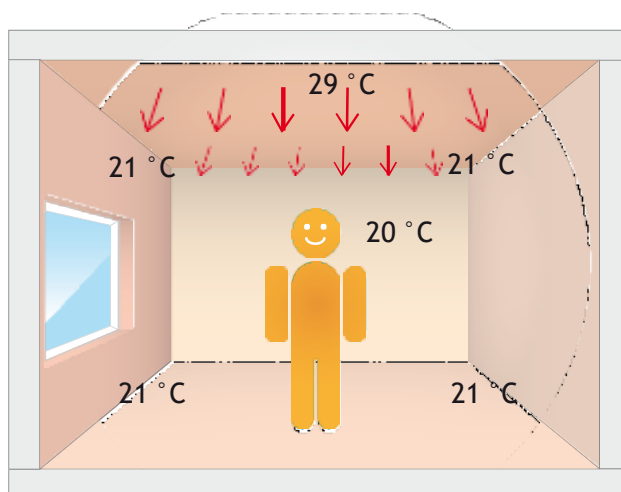

▲ Comfort with ceiling heating

- › Cooling, heating and a ready-to-install ceiling all in one
- › Available with acoustic function on request: With Variotherm the holes of the acoustic panels are not covered by cooling/heating elements! This is the only way to ensure certified, guaranteed noise reduction.
- › Ideal for timber frame construction, prefabricated house construction, attics and refurbishment
 - › As cooling: silent, no draughts, saves energy
 - › As heating: large-surface, extremely energy-saving low-temperature system
- › Totally flexible panel system for all constructional requirements
- › Building biology tested gypsum fibre boards and components
- › Fire resistance certification for ModularCeiling-Classic

3. Energysaving

Energy losses are significantly reduced while comfort is increased thanks to the optimised room air temperature. It is roughly estimated that approx. 6 % of heating costs are saved per 1 °C reduction in room air temperature during heating or per 1 °C increase in room air temperature during cooling. This has the additional significant physiological advantage, that for most people the body's oxygen intake is increased.

The ModularCeiling is ideal for use with low-temperature energy sources such as condensing boilers, heat pumps and solar collectors, as it operates with a low surface and heating medium temperature.

This means that energy savings of up to 30 % can be achieved with the Variotherm ModularCeiling compared to conventional heating systems.

4. Planning freedom

Due to the invisible cooling/heating ceiling, radiators or split-design units can be dispensed with during planning. This saves a lot of space and the interior can be designed freely: No restrictions on the wall and window layout or interior design. Only the ceiling lights and spots have to be taken into account.

1.5 Description and advantages of ModularCeiling

The Variotherm ModularCeiling is an extremely energy-saving cooling and heating system. As a flexible panel system it comes ready to be mounted on ceilings and pitched roofs. Cooling, heating and a ready-to-install ceiling are perfectly combined here in one solution! The desired room climate is achieved by means of hot and cold water circulation - so you can feel really comfortable all year round!

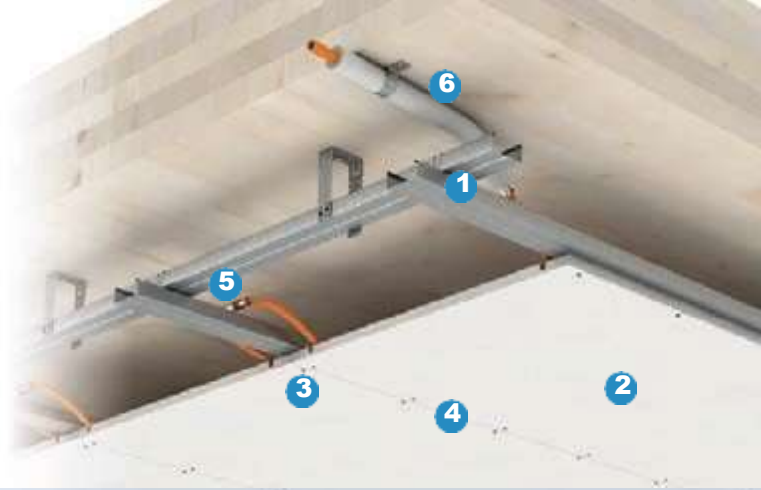

- 1 On-site prepared substructure (wood or metal)
- 2 ModularPanel
- 3 Dry wall screws
- 4 Joint adhesive
- 5 Press-fit coupling
- 6 Pre-insulated VarioModular pipe 16x2



ModularCeiling-Classic
for screwed ceiling constructions
Flexible panel system,
Fire resistance certification



ModularCeiling-Acoustic
for screwed ceiling construction
ModularPanels with noise-absorbing
surface

2 PREPARATION

1. Warranty conditions

If installed or commissioned incorrectly, all claims on the basis of the manufacturer's warranty and guarantee become void.

This brochure (version dated 12/2022) is intended for authorised qualified personnel and constitutes part of our warranty!

All previous versions become invalid upon release of a new version! For the latest version please refer to the QR Code on the title page or www.variotherm.com.

Local, geographic and climatic regulations/standards for cooling, heating and electrical installations must be observed!

2. Standards information

The validity of the standards indicated in these installation instructions was last verified on 28/11/2022!

Changes to standards must be checked if necessary!

3. Fire protection

With respect to fire protection, the Variotherm Modular-Panels 18 mm with integrated VarioModular pipes are equivalent to a 12.5 mm FERMACELL gypsum fibre board without pipes (Test IBS-Linz No. VFA2001-0389.01, fire protection assessment file number 10111710).

Please observe the relevant FERMACELL regulation and FERMACELL fire protection assessments. The Variotherm acoustic ModularPanels provide no fire protection! See also Chapter 4.

4. Load-bearing walls

Caution: With load bearing wall construction the Variotherm ModularPanels must not carry any static ceiling loads and must not be used for building reinforcement.

2.5 Goods transport/storage

Pre-insulated VarioModular pipes

Leave the VarioModular pipes in the box as long as possible to avoid damage from dents and scratches.

Damage of this kind has a detrimental effect on the creep behaviour.

The VarioModular pipes can be damaged by both atmospheric oxygen and UV rays and must not be stored outdoors.

At low temperatures (≤ 5 °C), the VarioModular pipe should be stored in heated rooms prior to processing.

VarioModular 11.6x1.5 pipe

The VarioModular pipe is completely integrated in the ModularPanel.

To prevent the VarioModular pipes being damaged during the construction phase by drilling or breaking work, clearly-visible warning labels must be affixed at appropriate points. Download in Infocenter at

www.variotherm.com.

In terms of weather resistance, the same instructions apply to the VarioModular 11.6x1.5 pipe as to the pre-insulated VarioModular 16x2 pipe.

ModularPanels

The ModularPanels are delivered on pallets. When storing, observe the load-bearing capacity of the storage location. The ModularPanels weigh 20.5 kg/m² and should always be stored flat on a level surface. If they are re-stacked during transport on the building site, the visible sides of the ModularPanels should be laid so that they face downwards.

They must be protected from moisture, especially rain. Panels that have become damp for a short time may only be handled after they have completely dried out.

Storing the panels vertically leads to deformation and damage to the edges. Transporting the panels horizontally within the building is possible using a pallet truck or other panel transport vehicle.

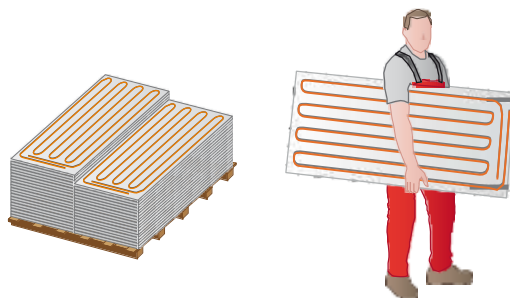

▲ Individual ModularPanels are best carried upright

2.6 Tools

Tools (on site) required/recommended for the installation work:

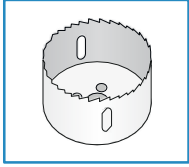

Hole saw

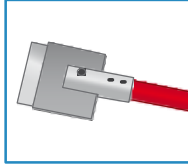

Adhesive scrapper



Cartridge gun

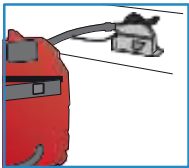

Circular saw or jigsaw

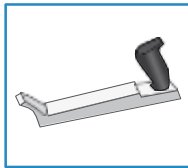

Plane for visible edges

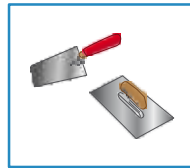

Trowel & plastering knife



Ceiling support



Power screw gun, preferably with depth stop



Clean bucket

Variotherm tools for connecting Variotherm pipes:



Pipe cutting pliers

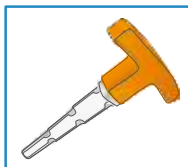

Calibration and chamfering tool

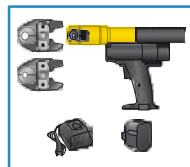

Pressing tools

2.7 Visible side/rear side of the ModularPanel

The visible side of the ModularPanel (= smooth side) faces into the room, the rear side (with the integrated VarioModular pipe) faces the substructure.

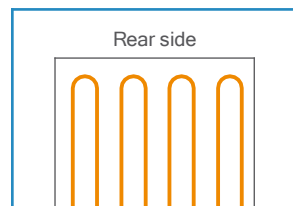
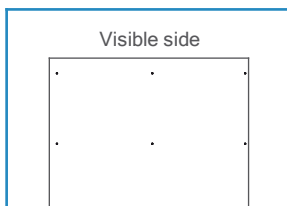

2.8 Humidity

The relative humidity must not exceed 70 % during storage, installation and additional processing of the ModularPanels and during the construction phase and normal use of the building. Wet plaster and wet screeds must be applied and have dried before the ModularPanels are installed.

The ModularPanels may be used in rooms up to humidity class W3 in accordance with ÖN B 3407 (or W1-I in accordance with DIN 18534-1).

2.9 Maximum flow temperature and dew point

Heating: The maximum flow temperature of the ModularPanels is 50 °C. For reasons of comfort $t_{mH} = 35 \text{ °C}$ ($t_r/t_r = 40/30 \text{ °C}$) should not be exceeded for the ModularCeiling. Cooling: The flow temperature must be selected in such a way or it must be ensured that the surface temperature of the ModularPanel (room-side and cavity) and the pipe never reaches or falls below the dew-point temperature at any point. Condensation can form on the pipes and surfaces if the flow temperature selected is too low. Control measures must be taken to prevent this (e.g. dew-point monitor, see Chapter 5.5).

2.10 Other work documents

Please also observe the latest FERMACELL planning and installation instructions! www.fermacell.com

3 SUBSTRUCTURE

1. General

Depending on the requirements, substructures are made of timber studs or metal profiles, with or without surface planking or cavity insulation or vapour retarders (vapour barriers). Please observe the instructions of the timber construction or the dry construction system manufacturers for the planning and installation of your ceiling construction.

- › In the case of wooden substructures, the timber used must be sufficiently dry and straight and must comply with ÖNORMEN 338 (grading class C24)
- › In the case of metal substructures, the profiles must be made of soft, non-alloyed steel with double-sided galvanising of at least 100 g/m² according to the ÖNORM DIN 18 182-1
- › The substructure must be designed to carry the weight of the ModularPanels (20.5 kg/m²) and any eventual additional loads (e.g. ceiling lights). Additional loads such as ceiling lights, multi-layer planking and other fittings must be taken into account separately! See also Chapter 6.3.
- › Do not glue the ModularPanels directly to the ceiling (plaster)

2. Spacing in the edge area

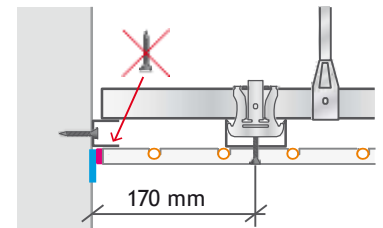
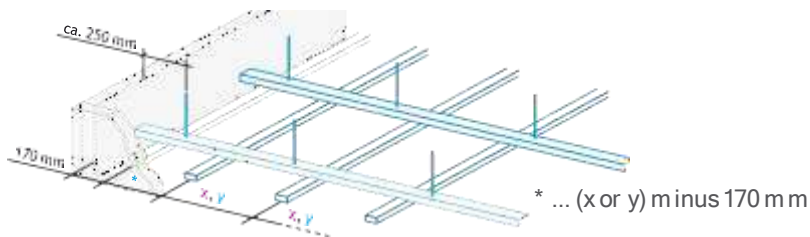

3.3 Basic battens/profiles (standard)

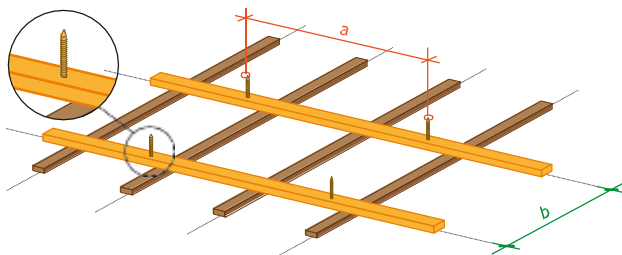

WOODEN SUBSTRUCTURE:
DIRECTLY FASTENED
MAIN JOISTS

	Joist dimensions w × h [mm]	Max. permissible span for loads of up to 30 kg/m ² ≙ ModularPanel (20.5 kg/m ²) + light additional load (up to 9.5 kg/m ²)	Max. permissible span for loads of up to 50 kg/m ² ≙ ModularPanel (20.5 kg/m ²) + heavy additional load (up to 29.5 kg/m ²)
Max. clearance direct attachment (a)	Main joists 48 × 24	650 mm	600 mm
	Main joists 50 × 30	750 mm	600 mm
	Main joists 60 × 40	850 mm	700 mm
Max. axis clearance main joists (b)	Cross joists 48 × 24	600 mm	500 mm
	Cross joists 50 × 30	750 mm	600 mm
	Cross joists 60 × 40	1000 mm	900 mm

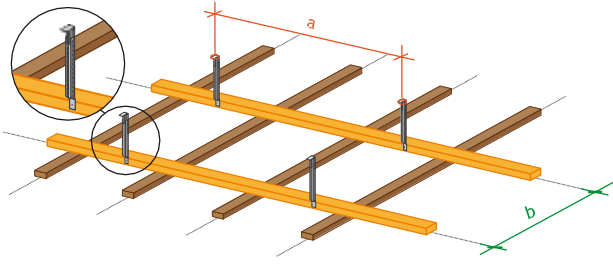

WOODEN SUBSTRUCTURE:
SUSPENDED MAIN JOISTS

	Joist dimensions w × h [mm]	Max. permissible span for loads of up to 30 kg/m ² △ ModularPanel (20.5 kg/m ²) + light additional load (up to 9.5 kg/m ²)	Max. permissible span for loads of up to 50 kg/m ² △ ModularPanel (20.5 kg/m ²) + heavy additional load (up to 29.5 kg/m ²)
Max. clearance direct attachment (a)	Main joists 30 × 50* Main joists 40 × 60	850 mm 1000 mm	700 mm 850 mm
Max. axis clearance main joists (b)	Cross joists 48 × 24 Cross joists 50 × 30 * Only in conjunction with cross joists that are 50 mm wide and 30 mm high	600 mm 750 mm 1000 mm	500 mm 600 mm 900 mm

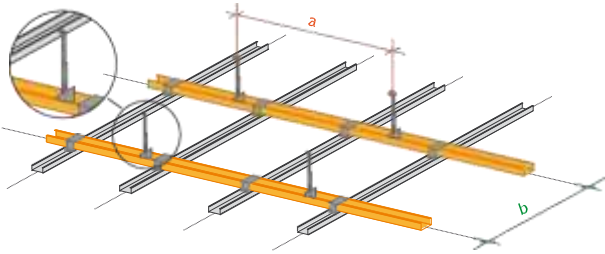

METAL SUBSTRUCTURE:
SUSPENDED MAIN PROFILE

	Profile dimensions** [mm]	Max. permissible span for loads of up to 30 kg/m ² △ ModularPanel (20.5 kg/m ²) + light additional load (up to 9.5 kg/m ²)	Max. permissible span for loads of up to 50 kg/m ² △ ModularPanel (20.5 kg/m ²) + heavy additional load (up to 29.5 kg/m ²)
Max. clearance suspension element (a)	Main profile CD 60 × 27 × 06	750 mm	600 mm
Max. axis clearance base profile (b)	Cross profile CD 60 × 27 × 06 ** Standard steel sheet profiles per EN 10359-1	1000 mm IN 18182 or ÖNORM EN 14195	750 mm

3.4 Support battens/profiles (without basic battens)

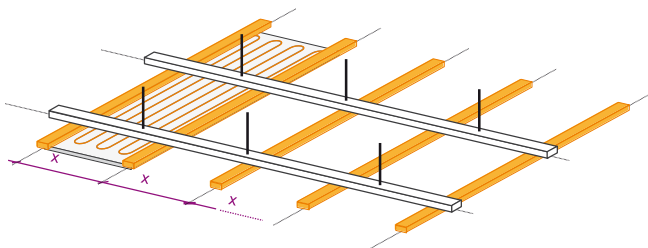

▲ Cross joists **longitudinal** to the ModularPanels

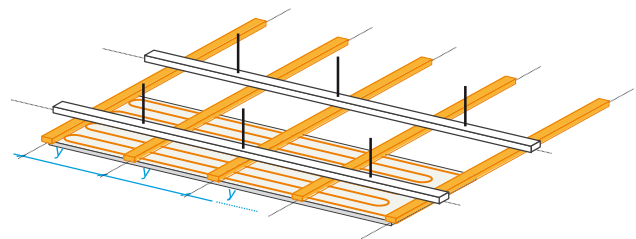

▲ Cross joists **transverse** to the ModularPanels

Panel size	ModularPanels-Classic									-Acoustic
	2500 × 625	2500 × 600	2000 × 625	2000 × 600	1500 × 625	1500 × 600	1000 × 625	1000 × 600	2000 × 312	
Max. axis clearance [mm]	625.0	600.0	625.0	600.0	625.0	600.0	625.0	600.0	312.0	625.0
longitudinal cross joists (x)	312.5	300.0	312.5	300.0	312.5	300.0	312.5	300.0	312.0	-
Max. axis clearance [mm]	416.7	416.7	500.0	500.0	375.0	375.0	500.0	500.0	500.0	500.0
transverse cross joists (y)	416.7	416.7	400.0	400.0	375.0	375.0	333.3	333.3	400.0	-

🔥 In the case of fire protection requirements, except where test verification/certification is otherwise specified

3.5 Support battens directly attached (without basic battens)

Due to the lower installation height with simple battens, it is necessary to interrupt the substructure approx. 200 mm after the end of the panel. This is followed by an intermediate space of 200 mm for supply pipes or press connections of the ModularPanels.

For axis clearance of the supporting battens, see Chapter 3.4.

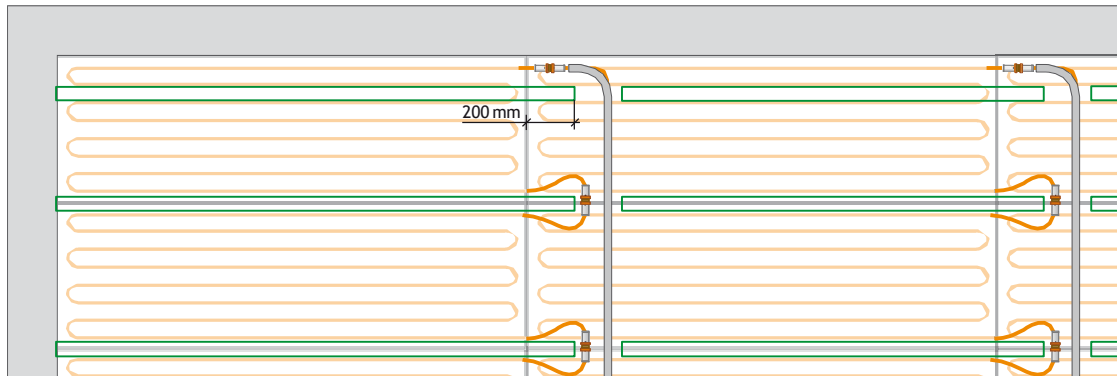

3.6 Movement joints

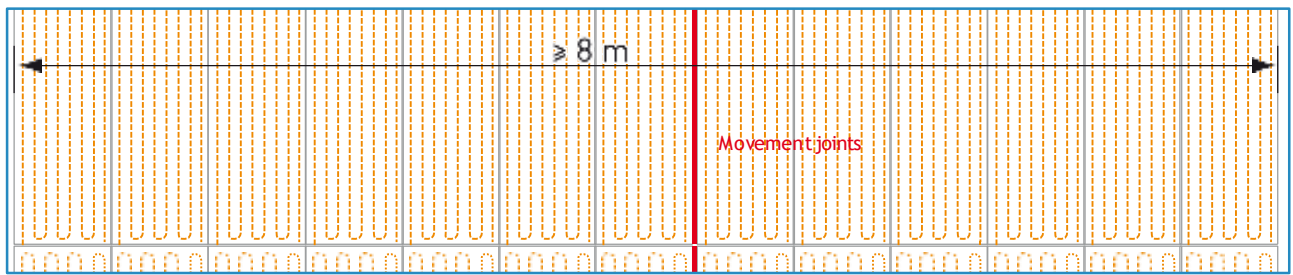

▲ Movement joint at e.g. 13x V020-100 (13x0.625 m = 8.13 m)

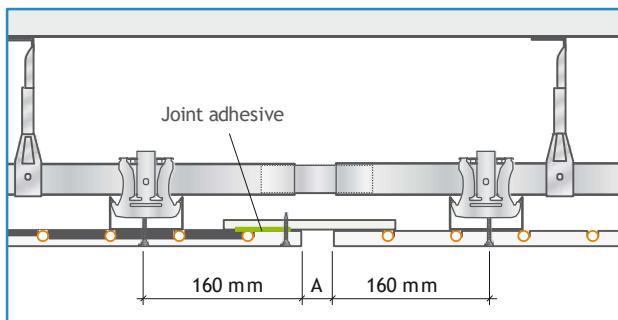

▲ Movement joint with panel strips,
A = movement dimension approx. 10-20 mm

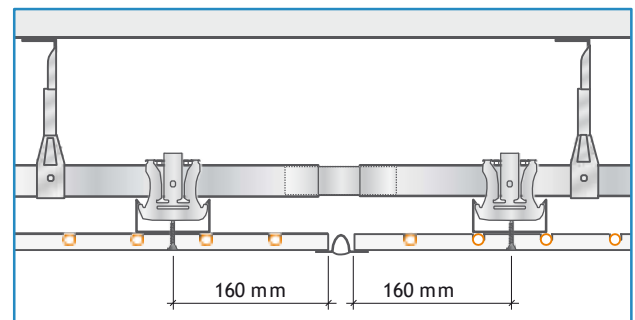

▲ Movement joint with additional profile

3.7 Insulation in substructure

If required, the cavity of the ceiling construction can be equipped with mineral wool. In combination with ModularPanels-Acoustic, the acoustic values can be improved even further (see also chapter 7).

Vapour-retarders cannot be installed. Care must be taken to ensure that the dew point is not reached within the mineral wool.

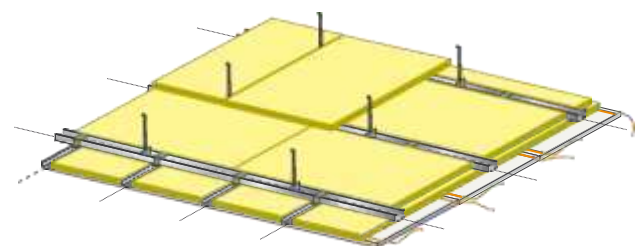

▲ Example of substructure insulation

4 FIRE PROTECTION



The **Variotherm Modular Panels 18 mm with integrated VarioModular pipes** are equivalent to a **12.5 mm FERMACELL gypsum fibre board without pipes** (Test IBS-Linz No. VFA2001-0389.01, fire protection assessment file number 10111710). Please observe the relevant FERMACELL regulation and FERMACELL fire protection assessments.



IBS - INSTITUT FÜR BRANDSCHUTZTECHNIK UND SICHERHEITSFORSCHUNG
Gesellschaft m. b. H.

IBS-ANSTALT FÜR BRANDSCHUTZTECHNIK UND SICHERHEITSFORSCHUNG
IBS-ANSTALT FÜR BRANDSCHUTZTECHNIK UND SICHERHEITSFORSCHUNG
IBS-ANSTALT FÜR BRANDSCHUTZTECHNIK UND SICHERHEITSFORSCHUNG

Variotherm Heizsysteme GmbH
Herr Ing. Thomas Baumgartner
Gürtelrieder Straße 3a
A-2544 Leobendorf

Datum: 17. November 2010
Aktennummer: 10111710
Bearbeiter: Dipl.-Ing. (FH) U. Böckl / hose
076 872

Brandschutzztechnische Beurteilung, Aktennummer: 10111710
Brandversuche entsprechend EN 1364, Teil 1 sowie EN 1365, Teil 2 sowohl eines unbelasteten Wandelementes als auch eines tragenden Deckenelementes der Firma Variotherm Heizsysteme GmbH

Aufgrund der in der Prüfstelle IBS Linz durchgeführten Brandprüfungen wird bestätigt, dass sowohl ein unbelastetes Wandelement als auch ein tragendes Deckenelement der Firma Variotherm Heizsysteme GmbH die Prüfanforderungen entsprechend EN 1364, Teil 1 sowie EN 1365, Teil 2 erfüllen.

Die Variotherm Modulplatten bestehend aus einer 18 mm Fercacell-Platte mit eingegliedertem Mehrschichtenrohr 11,6 x 1,6/Alu 0,20 mm wurden zwei Brandprüfungen unterzogen:

- 1.) Brandversuch einer nichttragenden Wand nach EN 1363-1 und EN 1364-1
Prüfbericht Nr.: 10060617
Prüfdatum: 31.08.2010
Prüfdauer: 45 Minuten und 20 Sekunden
Nach EN 13501-2 Kapitel 7.5.2 in die Feuerwiderstandsklasse EI 45 einzustufen
Der Brandversuch vom 31.08.2010 am IBS Linz wurde dem Versuch mit der Prüfbericht Nr.: PG10934 vom 12.04.2002 am Danish Institute of Fire and Security Technology nachgestellt, bei dem eine Versuchszeit von 35 Minuten erreicht wurde.
- 2.) Brandversuch eines tragenden Deckenelementes nach EN 1363-1 und EN 1365-2
Prüfbericht Nr.: 10060618
Prüfdatum: 28.09.2010

VARIO THERM
HEIZSYSTEME GMBH

English Translation according to „Brandschutzztechnische Beurteilung“:

Fire safety assessment, file number: 10111710

Fire tests in accordance with EN 1364, Part 1 as well as EN 1365, Part 2 on an unloaded wall element as well as on a load-bearing ceiling element of the company Variotherm Heizsysteme GmbH

On the basis of the fire tests carried out at the testing body IBS Linz, we hereby certify that both an unloaded wall element as well as a load-bearing ceiling element from the company Variotherm Heizsysteme GmbH satisfy the test requirements in accordance with EN 1364, Part 1 as well as EN 1365, Part 2.

The Variotherm modular panels, consisting of an 18 mm Fercacell panel with inserted multi-layer composite pipe 11.6x1.5/Alu0.20 mm, were subjected to two fire tests:

- 1.) Fire test on a non-load-bearing wall as per EN 1363-1 and EN 1364-1
1 Test report no.: 10050617
Test date: 31/08/2010
Test duration: 45 minutes and 20 seconds
In accordance with EN 13501-2 Section 7.5.2 to be classified under the fire resistance category EI45
The fire test dated 31/08/2010 at the IBS Linz was a reconstruction of the trial as per test report no.: PG10934 dated 12/04/2002 at the Danish Institute of Fire and Security Technology in which a trial duration of 35 minutes was achieved.
- 2.) Fire test on a load-bearing ceiling element as per EN 1363-1 and EN 1365-2
Test report no.: 10050618
Test date: 28/09/2010
Test duration: 100 minutes and 20 seconds
In accordance with EN 13501-2 Section 7.3.3 to be classified under the fire resistance category REI90
The fire test dated 28/09/2010 at the IBS Linz was a reconstruction of the trial as per test report no.: MA39-VFA 2002-2173.01 dated 14/04/2003 at the Municipal Department 39 of the Research and Testing Institute of the City of Vienna in which a trial duration of 94 minutes was achieved.

Fire safety assessment

The fire tests carried out at the IBS were identical in terms of their structure to the fire tests carried out at the above mentioned testing institutes, with the difference that the 12.5 mm thick Fercacell panels facing the fire were replaced by 18 mm thick Variotherm modular panels.

On the basis of the test results available as per ÖNORM EN 1364, Part 1 as well as ÖNORM EN 1365, Part 2, it can be ascertained that at least identical results were achieved with the 18 mm thick Variotherm modular panels as with the 12.5 mm thick Fercacell panels, meaning that there is direct comparability.

It can therefore be confirmed that, in lightweight constructions (walls, ceilings, pitched roofs), the normal 12.5 mm thick Fercacell panels can be replaced by 18 mm thick Variotherm modular panels without disadvantages in terms of the fire resistance.

IBS - INSTITUT FÜR BRANDSCHUTZTECHNIK UND SICHERHEITSFORSCHUNG GESELLSCHAFT M. B. H.
Accredited testing and inspection body

Examples of fire protection structures

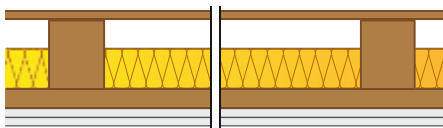

Ceiling construction with 12.5 mm Fercacell gypsum fibre boards

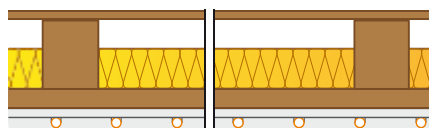

with Variotherm ModularPanel

Fire resistance as per EN 13501-2: **REI 60***

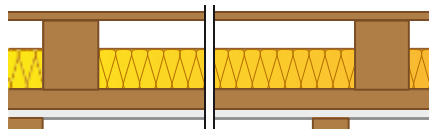
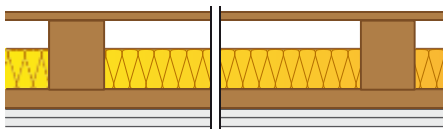

Fire resistance as per EN 13501-2: **REI 60***
(Variant with intermediate battens; also confirmed by IBS Linz)

* For details regarding wall fittings, please refer to the Fercacell planning documents.

5 COMPONENTS

5.1 ModularPanels / ModularExpansionPanels - Overview

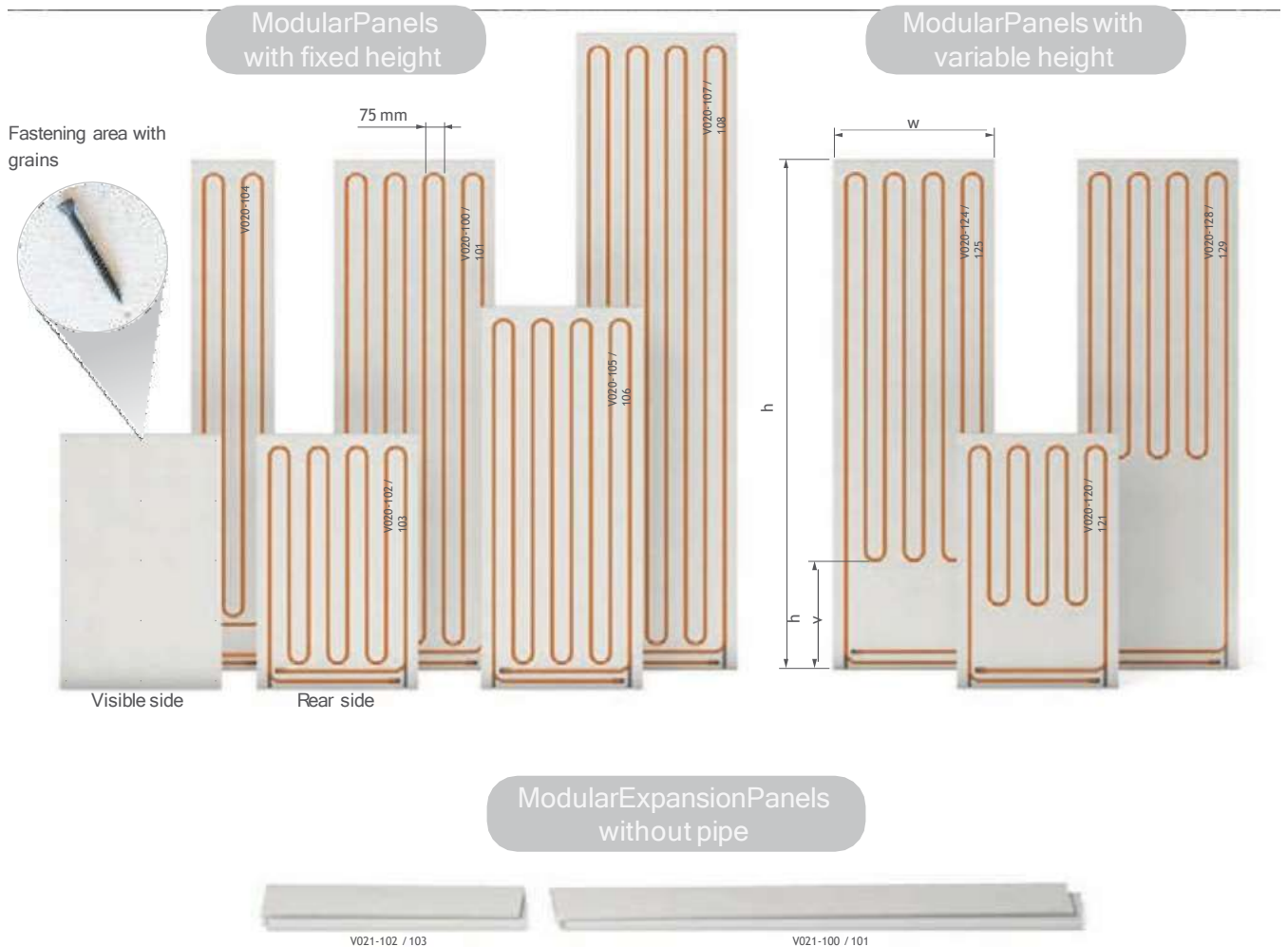

The ModularPanels are 18 mm thick, environmentally safe-tested gypsum fibreboards. The VarioModular 11.6x1.5 pipes are already integrated in the back of the panels. The axis clearance of the pipes is 75 or 105 mm

Panels with either fixed or variable height are available:

Fixed height: The entire surface of the ModularPanel is laid with pipes and serves as a heating/cooling surface.

Variable height: Only part of the panel is laid with pipes and serves as a heating/cooling surface, the unused area (hv) can be cut to size individually or, for example, be used as a recess for sockets.

Panel technical data:

Panel: Building biology tested gypsum fibre board

Fire resistance as per EN 13501-1:
non-flammable, A2

Identification as per EN 15283-2:
GF-I-W2-C1

Thermal conductivity λ : 0.32 W/m K

Apparent density ρ_K : 1150 \pm 50 kg/m³

Water vapour diffusion

resistance factor μ : 13



ModularPanels with fixed height
(pipe spacing 105 mm)

Special solutions
(on request)

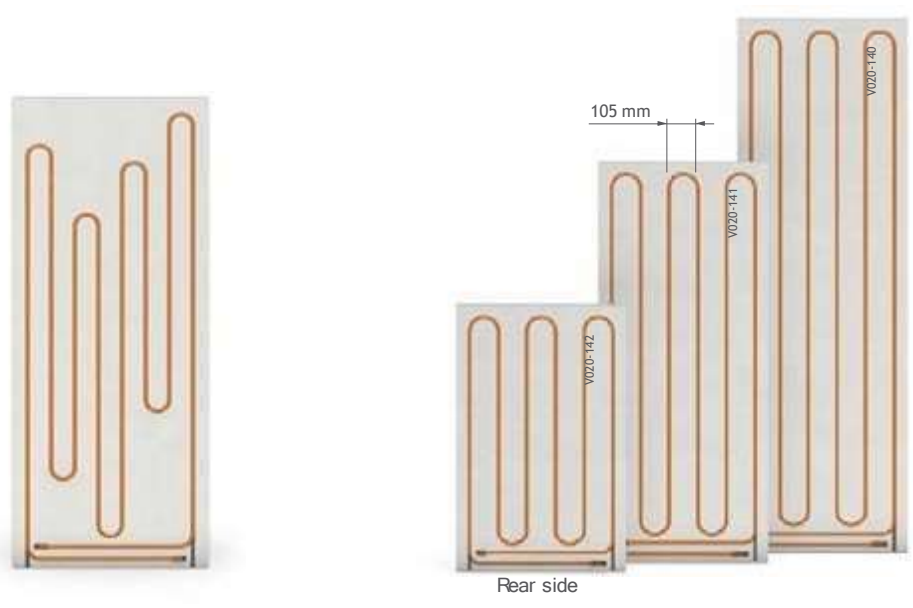

<< **Large pipe spacing**
Ideal for light spots up to mounting diameter \varnothing 80 mm

ModularPanels with acoustic function

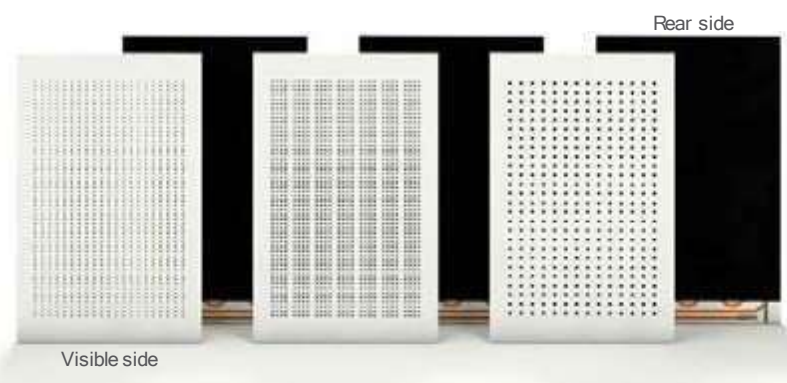

ModularPanels- Acoustic
3 different hole patterns.
Noise-absorbing acoustic surface
Rear side covered with acoustic fleece.
>> Details see Chapter 7.



Overview of the ModularPanels/ModularExpansionPanels

Part no.	Product code / Colour code	Pipe spacing [mm]	Dimensions (h × w), [mm]	Height h _v [mm]	Panel surface [m ²]	Effective surface [m ²]	Laid pipe in panel	Weight/ panel	Required quantity ¹ dry wall screws 3.9 × 40 mm				
									Longitudinal joists	Transverse joists			
ModularPanels-Classic										🔥		🔥	
V020-100	MDC-2000-625	75	2000 × 625	-	1.25	1.25	16.2 m	25.5 kg	2 × 9 pcs.	3 × 11 pcs.	5 × 5 pcs.	6 × 5 pcs.	
V020-101	MDC-2000-600	75	2000 × 600	-	1.20	1.20	16.2 m	24.5 kg					
V020-102	MDC-1000-625	75	1000 × 625	-	0.63	0.63	8.2 m	12.8 kg	2 × 5 pcs.	3 × 6 pcs.	3 × 3 pcs.	4 × 5 pcs.	
V020-103	MDC-1000-600	75	1000 × 600	-	0.60	0.60	8.2 m	12.2 kg					
V020-104	MDC-2000-312	75	2000 × 312	-	0.62	0.62	8.2 m	12.6 kg	2 × 9 pcs.	2 × 11 pcs.	5 × 2 pcs.	6 × 3 pcs.	
V020-105	MDC-1500-625	75	1500 × 625	-	0.94	0.94	12.2 m	19.2 kg	2 × 7 pcs.	3 × 9 pcs.	5 × 3 pcs.	5 × 5 pcs.	
V020-106	MDC-1500-600	75	1500 × 600	-	0.90	0.90	12.2 m	18.4 kg					
V020-107	MDC-2500-625	75	2500 × 625	-	1.56	1.56	20.2 m	33.8 kg	2 × 11 pcs.	3 × 14 pcs.	7 × 3 pcs.	7 × 5 pcs.	
V020-108	MDC-2500-600	75	2500 × 600	-	1.50	1.50	20.2 m	30.6 kg					
V020-120	MDC-1000-625-V300	75	1000 × 625	300	0.63	0.48	6.7 m	13.0 kg	2 × 9 pcs.	3 × 11 pcs.	5 × 5 pcs.	6 × 5 pcs.	
V020-121	MDC-1000-600-V300	75	1000 × 600	300	0.60	0.46	6.7 m	12.5 kg					
V020-124	MDC-2000-625-V400	75	2000 × 625	400	1.25	1.04	14.2 m	25.8 kg	2 × 9 pcs.	3 × 11 pcs.	5 × 5 pcs.	6 × 5 pcs.	
V020-125	MDC-2000-600-V400	75	2000 × 600	400	1.20	1.00	14.2 m	24.8 kg					
V020-128	MDC-2000-625-V800	75	2000 × 625	800	1.25	0.79	11.8 m	26.2 kg	2 × 9 pcs.	3 × 11 pcs.	5 × 5 pcs.	6 × 5 pcs.	
V020-129	MDC-2000-600-V800	75	2000 × 600	800	1.20	0.76	11.8 m	25.1 kg					
V020-14	MDC-2000-625-105	105	2000 × 625	-	1.25	1.25	12.3 m	25.6 kg	2 × 7 pcs.	3 × 9 pcs.	5 × 3 pcs.	5 × 5 pcs.	
0	MDC-1500-625-105	105	1500 × 625	-	0.94	0.94	9.3 m	19.2 kg	2 × 5 pcs.	3 × 6 pcs.	3 × 3 pcs.	4 × 5 pcs.	
1	MDC-1000-625-105	105	1000 × 625	-	0.63	0.63	6.3 m	12.9 kg					
V020-14													
2													

¹ Spread out bolts evenly across the length/width of the panel.

🔥 If the class of fire protection requirements, except where test verification/certification is otherwise specified.

Part no.	Product code / Colour code	Pipe spacing [mm]	Dimensions (h × w), [mm]	Height h _v [mm]	Panel surface [m ²]	Effective surface [m ²]	Laid pipe in panel	Weight/ panel	Required quantity1 dry wall screws 3.9 × 40 mm		
									Longitudinal joists	Transverse joists	
ModularExpansionPanels-Classic											
V021-100	MAC-2000-625	-	2000 × 625	-	1.25	without pipe	27.1 kg	2 × 9 pcs.	5 × 5 pcs.		
V021-101	MAC-2000-600	-	2000 × 600	-	1.20	without pipe	26.0 kg				
V021-102	MAC-1000-625	-	1000 × 625	-	0.63	without pipe	13.6 kg	2 × 5 pcs.	3 × 3 pcs.		
V021-103	MAC-1000-600	-	1000 × 600	-	0.60	without pipe	13.0 kg				

1 Spread out bolts evenly across the length/width of the panel.

🔥 In the case of fire protection requirements, except where test verification/certification is otherwise specified

Overview of the ModularPanels-Acoustic/ModularExpansionPanels-Acoustic

Part no.	Product code / Colour code	Pipe spacing [mm]	Dimensions (h × w), [mm]	Panel surface [mm]	Effective surface [mm]	Laid pipe in	Weight/ [m ²]	Required quantity1 dry wall screws 3.9 × 40		
								Longitudinal [m]	Transverse [m]	
ModularPanels-Acoustic										
V024-109	MDA-1000-625-F06	75	1000 × 625	6 25 16 [mm]	0.63	0.63	8.5 m	8.4 kg	2 × 5 pcs.	3 × 3 pcs.
V024-104	MDA-1000-625-B08	75	1000 × 625	8 15 16 [mm]	0.63	0.63	8.5 m	10.5 kg	2 × 5 pcs.	3 × 3 pcs.
V024-110	MDA-1000-625-F12	75	1000 × 625	12 37.5 32 [mm]	0.63	0.63	8.5 m	12.4 kg	2 × 5 pcs.	3 × 3 pcs.
ModularExpansionPanels-Acoustic										
V021-113	MAA-1000-625-F06	-	1000 × 625	6 25 16 [mm]	0.63	without pipe		12.7 kg	2 × 5 pcs.	3 × 3 pcs.
V021-108	MAA-1000-625-B08	-	1000 × 625	8 15 16 [mm]	0.63	without pipe		11.6 kg	2 × 5 pcs.	3 × 3 pcs.
V021-114	MAA-1000-625-F12	-	1000 × 625	12 37.5 32 [mm]	0.63	without pipe		12.5 kg	2 × 5 pcs.	3 × 3 pcs.
V021-102	MAA-1000-625	-	1000 × 625	-	0.63	without pipe		13.6 kg	2 × 5 pcs.	3 × 3 pcs.

1 Spread out bolts evenly across the length/width of the panel.

5.2 ModularPanels / ModularExpansionPanels- Installation

- › Dry wall screw 3.9 x 40 m m
- › Part No.:
F120-0250 (PKU: 250 pcs.)
F120-1000 (PKU: 1000 pcs.)
- › Weight/PKU:
0.6 kg (F120-0250)
2.4 kg (F120-1000)
- › Consumption: 16 pcs./m²
- › Optimum shank length
- › Incl. associated bit



- › Greenline joint adhesive
- › Part No.: F111
- › PKU: 1 cartridge
Carton with 25 cartridges
- › Weight/PKU: 550 g
- › Consumption: ~7 m² / cartridge
- › For connecting the blunt adjoining ModularPanels

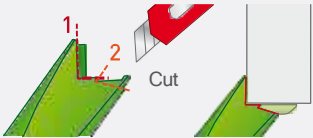

A tip from Variotherm: Cut off the cartridge tip as shown in the illustration.

- › Adhesive tape
- › Part No.: V288
- › Weight/PKU: 210 g
PKU: 1 pce.
Carton with 36 pcs.
- › As a separating layer to joint surfaces or between the panel contact points and the substructure (if required)



A tip from Variotherm: Use a power screw gun if possible and set the penetration depth of the screw head to approx. 0.1 mm.

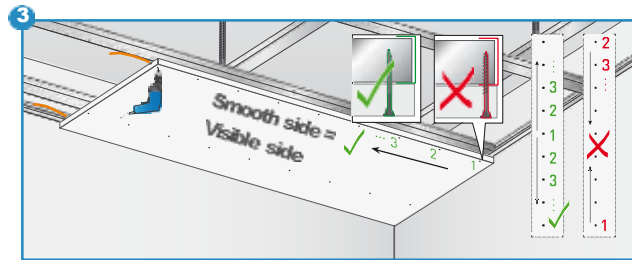
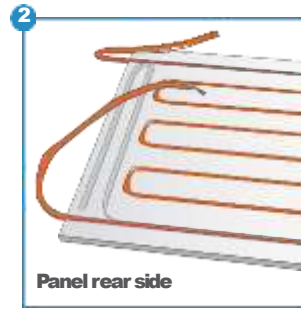
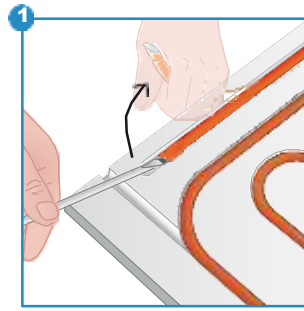

The ModularPanel is installed in the fastening area (see page 20/21) with the 3.9 x 40 mm dry wall screws.

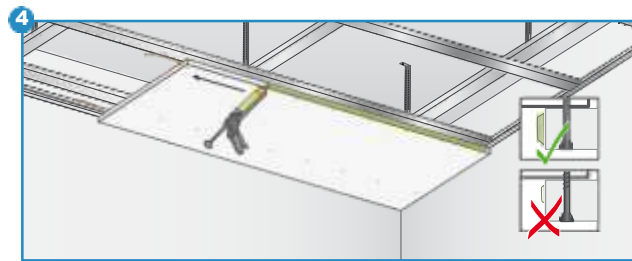

Apply greenline joint adhesive in flat bulge shapes (width around 14 mm) to the well-dusted panel edge. Processing temperature: Adhesive > 10 °C, room temperature > 5 °C.

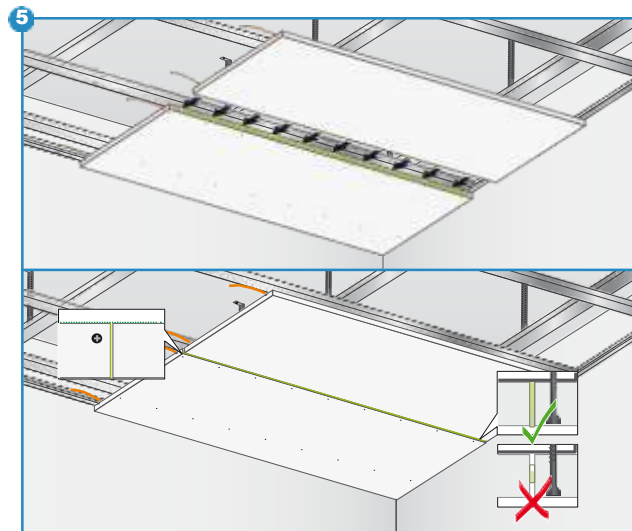

Press the second ModularPanel against the first one so that the joint is tight. The joint width must not exceed 1 mm. Leave the joint adhesive approx. 18 to 36 hours to harden and only afterwards scrape off any excess (see also Chap. 6.1).

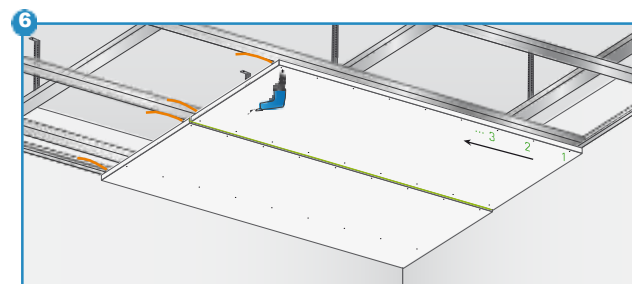

Screw the second ModularPanel in the correct order and repeat with each additional ModularPanel.

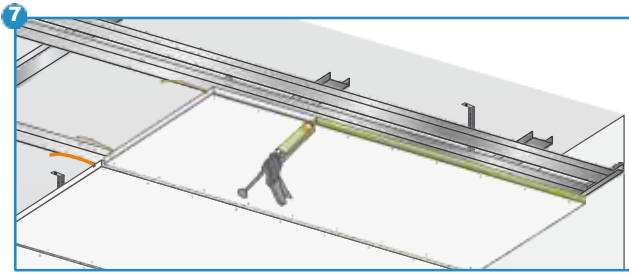

The remaining areas to the side of the ModularPanels are filled with ModularExpansionPanels. Mounting is carried out 1:1 as with the ModularPanels.

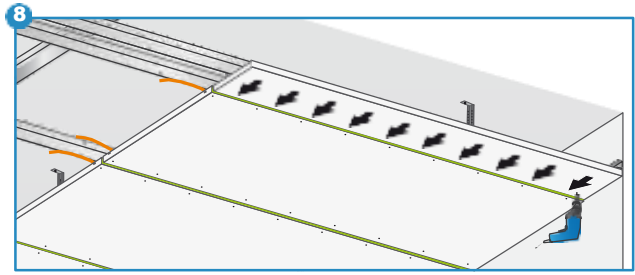

For cut panel edges (handheld circular saw), it should be noted that cut edges must be dusted directly and immediately before the application of the joint adhesive. Cross joints should be avoided.

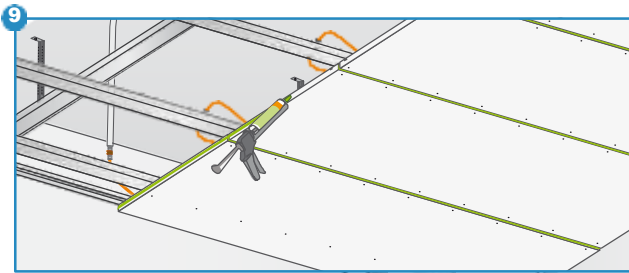

Before starting the next row of panels, the supply pipes or ModularPanels are pressed together (see Chapter 5.4).

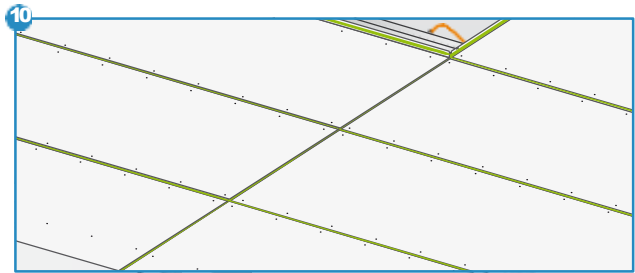

Adapt the ModularPanels

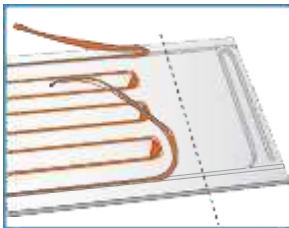

▲ Shorten the variable ModularPanel in length

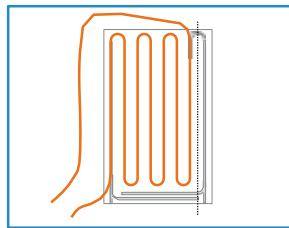

▲ Shorten the Modular-Panels in width

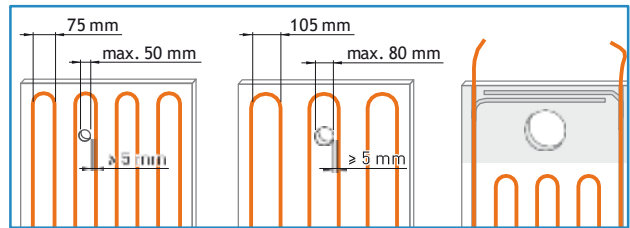

▲ Cut-out for blank piping, light spots, etc.

Transitions to other panel materials

Different materials expand in different ways. Therefore, a ceiling surface should be installed with the same panel material throughout.

Variotherm provides no warranty for transitions to other board materials (for example gypsum plasterboards). Please observe the guidelines of the respective (panel) manufacturers.

As a possibility for transitions, we can provide the following examples from practice:

- › Grouted joints (approx. 7 mm) with a separating layer (= decoupled connection).
Advantage: intentional straight crack (usually hardly visible)
- › Elastic seams (acrylic mass).
(maintenance seam, not permitted for fire-resistant constructions)
- › Fascia
- › Wooden strip fixed on one side for covering the transition

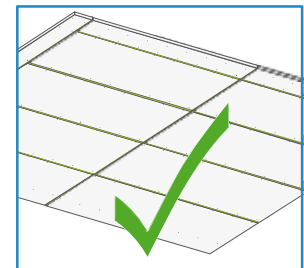

▲ Gypsum fibre boards

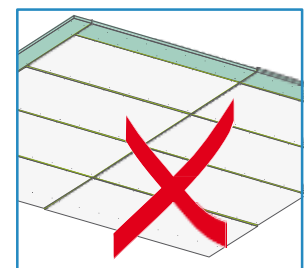

▲ Gypsum fibre boards and Gypsum plasterboards

Fastening area of the Modular Panels- (pipe spacing 75 mm) batten lengthwise

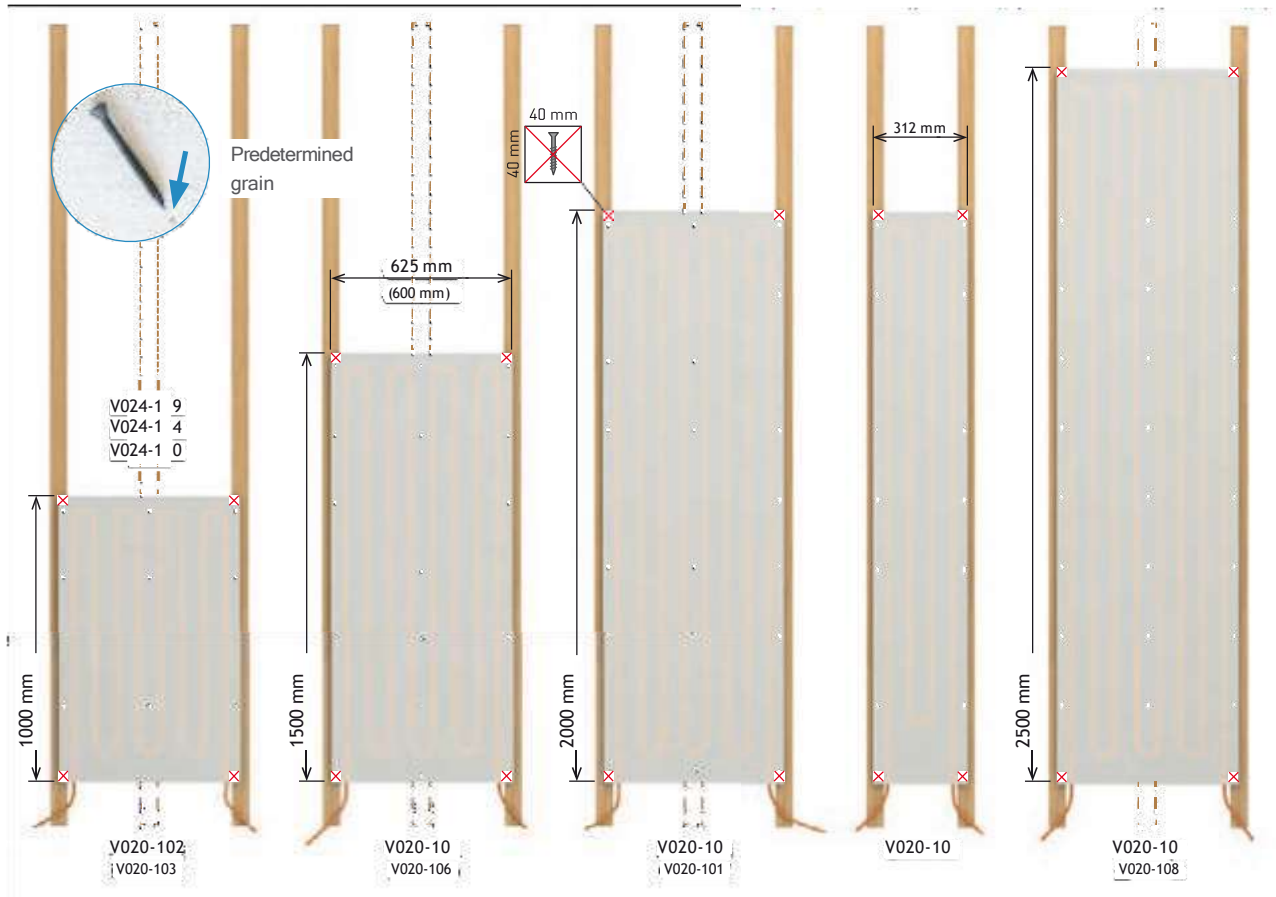

Fastening area of the Modular Panels- (pipe spacing 75 mm) batten crosswise

Spacing of the battens depends on the panel height (see Chapter 3).
Predetermined grain CANNOT be used.

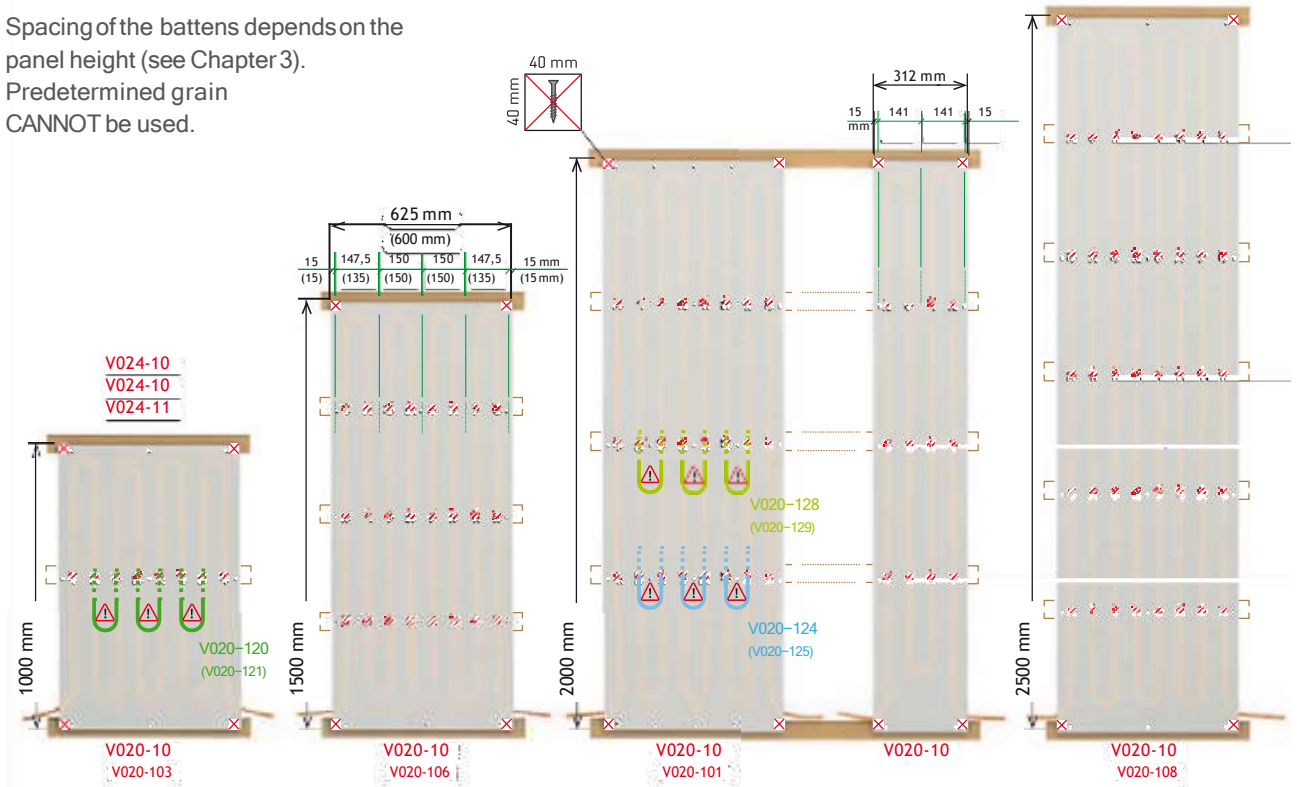

Fastening area of the ModularPanels- (pipe spacing105mm) batten lengthwise

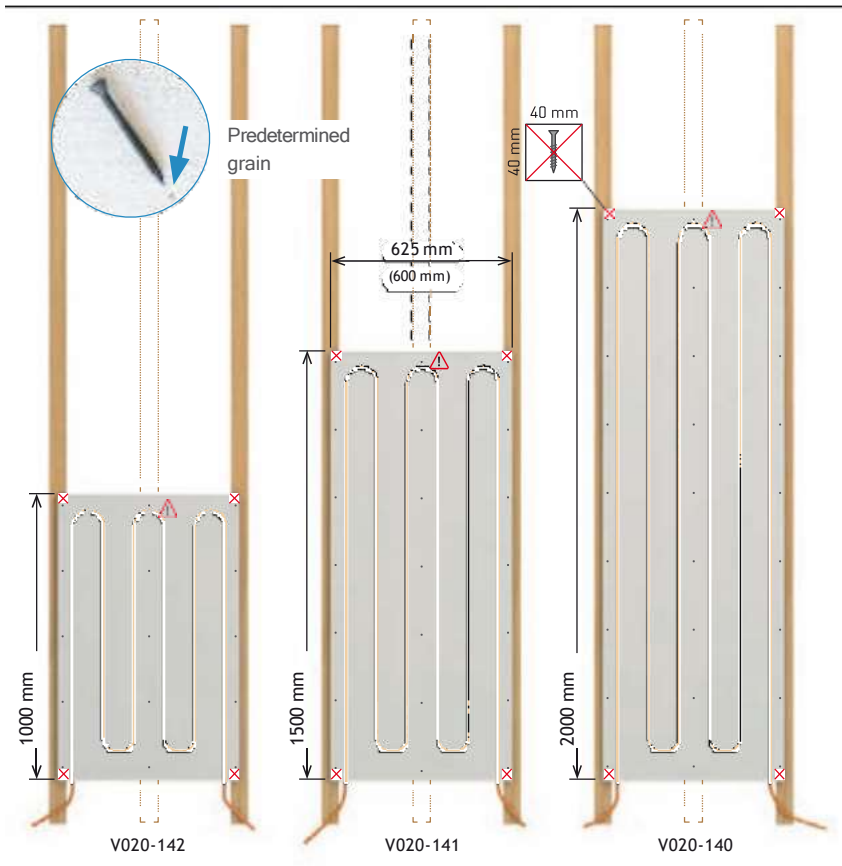

Fastening area of the ModularPanels- (pipe spacing105mm) batten crosswise

Spacing of the battens depends on the panel height (see Chapter 3).
 Predetermined grain
 CANNOT be used.

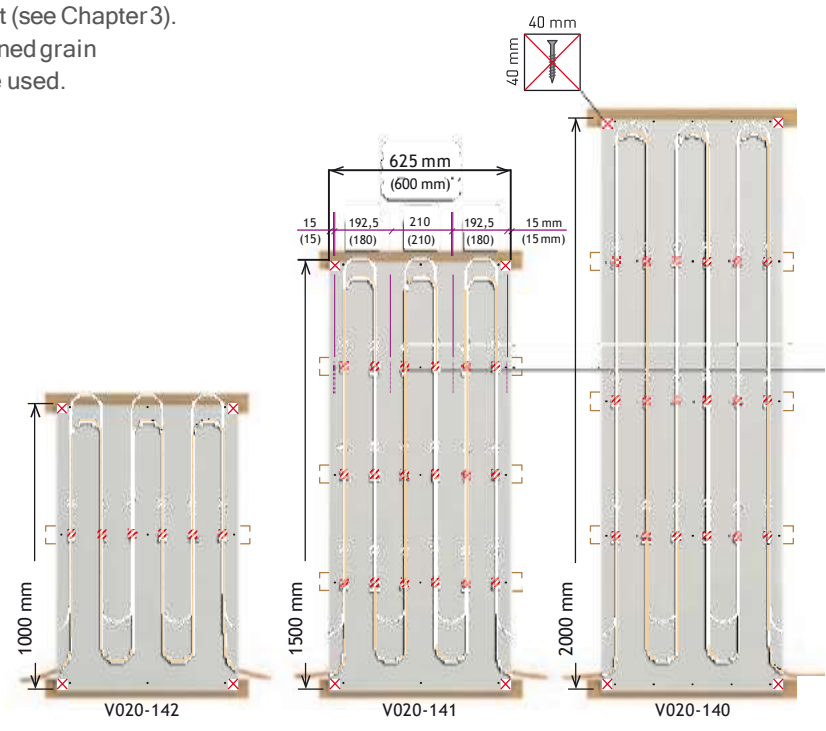

Panel connections

Connections to walls or pitched roofs are to be constructed as grouted joints (approx. 7 mm) with a ■ separating layer ■ or using termination angles (decoupled connections)

Caution: Pay attention to the VarioModular pipes when fastening the ModularPanels in the connection areas (deviation from fastening area)!

For further information on filling, see also Chapter 6.1!

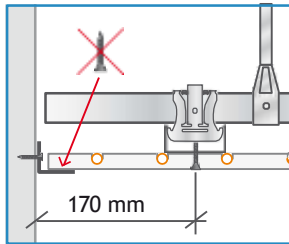

▲ Connection with termination angle

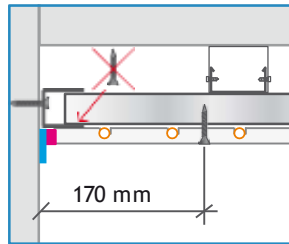

▲ Connection with UD profile - battens transverse to the panel

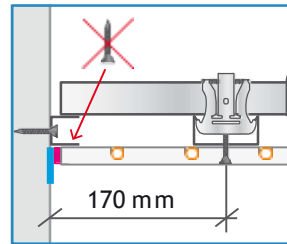

▲ Connection with UD profile - battens longitudinal to the panel

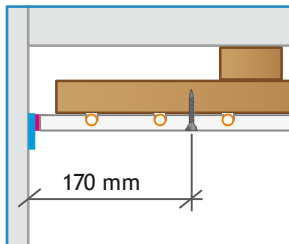

▲ Connection with separating strip

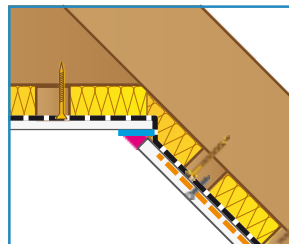

▲ ModularCeiling to roof pitch

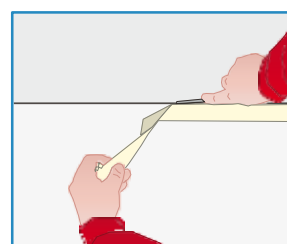

▲ The protruding separating layers (adhesive tape ■) are only removed after filling!

Movement joints

Movement joints are to be provided every 8 m in ceiling constructions.

Caution: Pay attention to the VarioModular pipes when fastening the ModularPanels in the area of the movement joints!

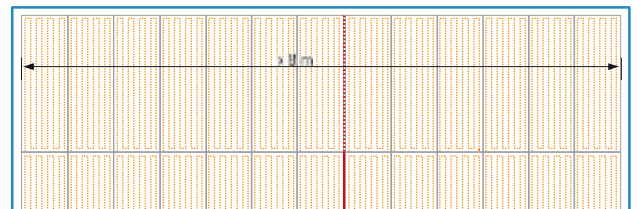

▲ Movement joint at e.g. 13× V020-100 ($13 \times 0.625 \text{ m} = 8.13 \text{ m}$)

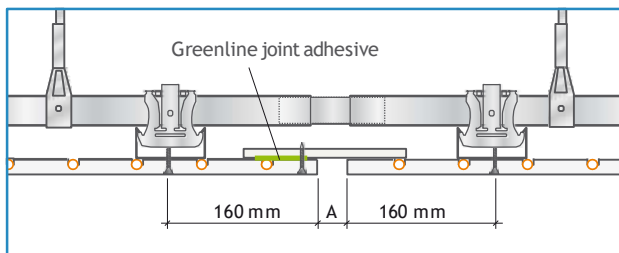

▲ Movement joint with panel strips, $A = 10\text{-}20 \text{ mm}$ (movement dimension)

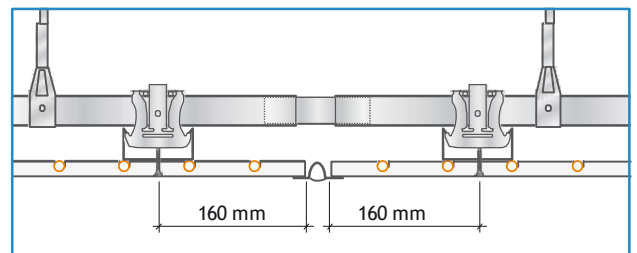

▲ Movement joint with additional profile

Panel installation between already installed Modular Panels

If "step-by-step" installation of the Modular Panels is not possible, proceed as follows:

- 1 Glue one side of the Modular Expansion Panel using greenline joint adhesive.
- 2 Leave a 3 to 8 mm gap on the other side.
- 3 Completely fill the gap with **Variotherm Duo adhesive** (special **W048 manual applicator** required!).

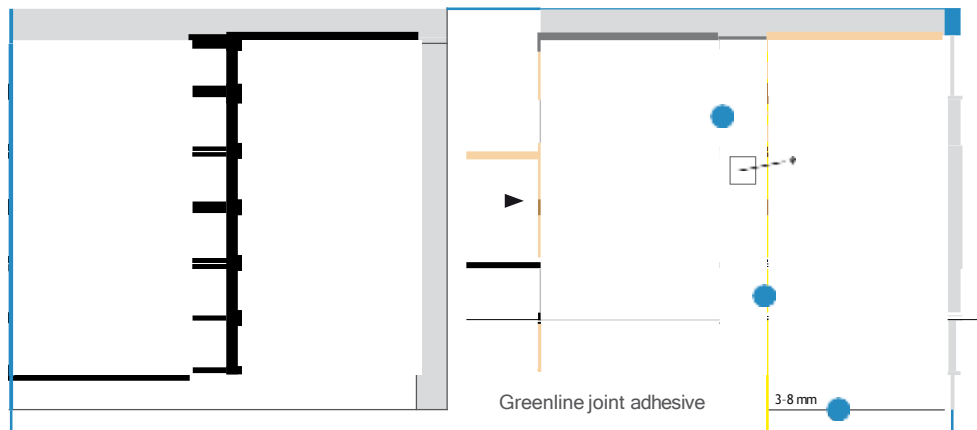

*e. g. inspection opening, from RUG Semin or UPMANN with 18 mm plasterboard insert. Please observe the installation instructions of the manufacturer!

Processing the Duo Adhesive:

- › The surfaces of the Modular Panels must be clean, dry, dust-free and grease-free.
- › Open the cartridge - screw on the static mixing tube.
- › Insert the cartridge into the Duo manual applicator.
- › For safety reasons, do not use the first amount of mixed adhesive for gluing (20 g, approx. walnut-sized).
- › Completely fill the joint from the top to the bottom using the static mixing tube.
- › For a better filling result, use a pointing trowel (or similar) to slightly hollow out the fresh joint.
- › Remove excess adhesive when still fresh. Hardened adhesive can only be removed with great effort.
- › The static mixing tube remains on the cartridge unit at the end of work/during breaks - the static mixing tube is then replaced the next time work begins again.
- › The joint can be covered with filler 4 hours after gluing the panels (working temperature > +15 °C).

Safety information:

Keep out of the reach of children! For further information see the product label or the safety data sheets according to Regulation 1907/2006/EC, Annex II, available at www.variotherm.com/en/service/info-centre/safety-data-sheets.html.

Wear suitable protective gloves. Protect your skin, eyes, clothing and tools from coming into contact with unhardened Duo adhesive. In the case of skin contact clean immediately with soap and water. Clean contaminated tools immediately with universal thinner. Hardened adhesive can only be removed mechanically.

Technical data:

Basis: 2-component PUR reaction adhesive

Colour when hard: beige

Viscosity at +20 °C: low-viscosity paste

Working time (at +10/+20/+30 °C): approx. 60/30/15 minutes

Hardening time (+20 °C, 50 % relative humidity): approx. 24 hours, final hardness after approx. 7 days

Working temperature: minimum of +7 °C to a maximum of +30 °C

Net weight: 900 g (2 × 310 ml tandem cartridge)

Consumption: 1 cartridge is sufficient for an approx. 7 m joint (4 mm width and 18 mm depth)

Storage: unopened, in a dry place at +15 °C to +25 °C approx. 15 months

- › Duo Adhesive
- › Part No.: F115
- › PKU: 1 Cartridge
Carton with 10 cartridges
- › Weight/PKU: 1 kg
- › Consumption: ~7 m joint
(4 mm width, 18 mm depth)
- › Special manual applicator W048 required!



- › Static mixing tube
- › Part No.: F116
- › PKU: 1 pce.
Carton with 75 pcs.
- › Weight/PKU: 15 g
- › Consumption: ~3 pcs./cartridge



- › Duo manual applicator
- › Part No.: W048
- › PKU: 1 pce.
Weight/PKU: 1.4 kg
- › The matching manual applicator for applying the Duo adhesive.





5.3 VarioModular pipes

- 1 Temperature-resistance polyethylene (PE)
- 2 Adhesive layer
- 3 Homogeneous and solid aluminium pipe
- 4 Adhesive layer
- 5 Raised-temperature-resistance polyethylene (PE-RT)

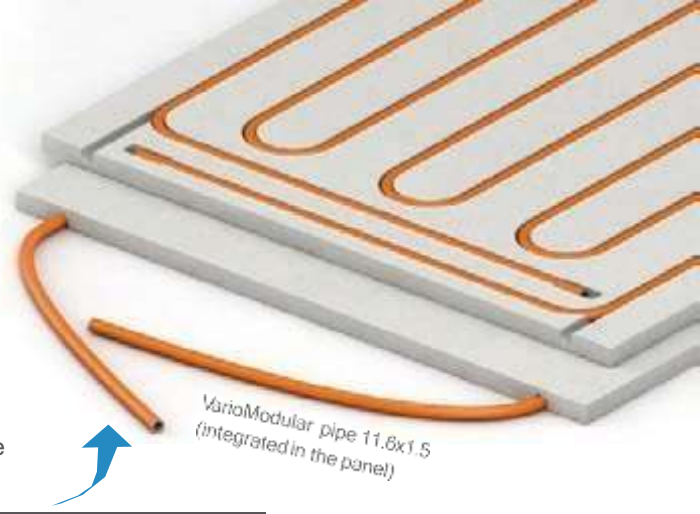

Technical data	11.6x1.5	(pre-insulated) 16x2
Pipe diameter	11.6 mm	16.0 mm
Pipe wall thickness	1.5 mm	2.0 mm
Aluminium pipe thickness	0.15 mm	0.18 mm
Water content	0.058 l/m	0.113 l/m
Special narrow bending radius (use a suitable bending device)	30 mm	40 mm
Max. operating temperature [t _{max}]	70 °C	70 °C
Short-term resistant [t _{ma}]	95 °C	95 °C
Max. operating pressure [p _{max}]	6 bar	6 bar
Linear expansion coefficient	2.3 × 10 ⁻⁵ [K ⁻¹]	2.3 × 10 ⁻⁵ [K ⁻¹]
Mean heat conduction coefficient [λ]	0.44 W/mK	0.45* W/mK
Heat transmission resistance	0.0034 m²K/W	0.0045* m²K/W



Pre-insulated VarioModular pipe 16x2 (supply pipe), Insulation thickness 6 or 9 mm

<< * Values without insulation

Advantages

- > Fully corrosion-free
- > Optimum creep behaviour
- > Just as light as a plastic pipe
- > 10-year guarantee with certificate
- > Flexible, easy to bend, extremely stable for m
- > Resistant to hot water additives (inhibitors, antifreeze)
- > Mirror-smooth inner surface - less pressure loss - no encrustation
- > High pressure and temperature resistance
- > 100 % oxygen diffusion-tight
- > Low linear coefficient of expansion, low heat expansion forces
- > Tested as per EN 21003

Creep behaviour

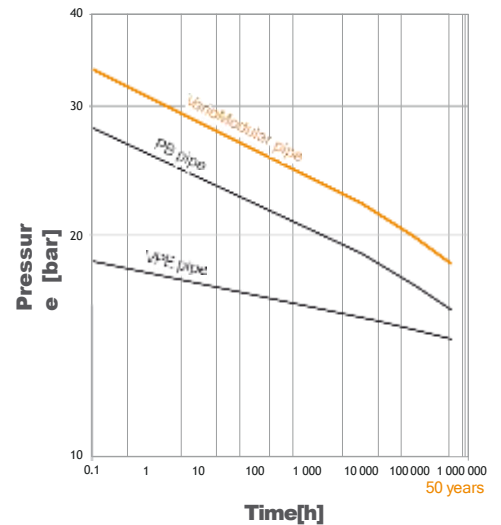

Elongation

with 10 m and temperature difference Δt 25 °C (e.g. 20 °C to 45 °C)

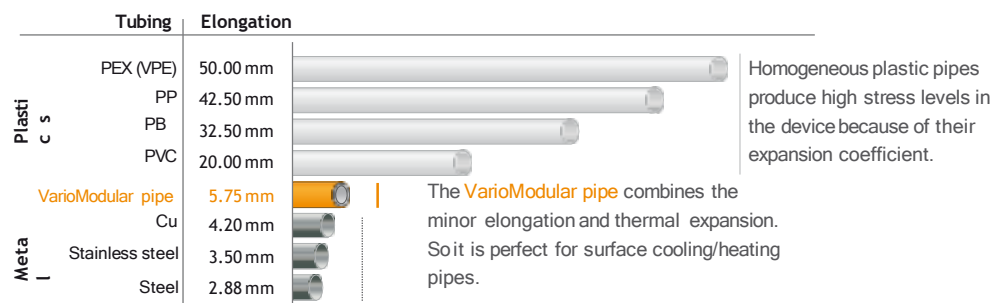

- > Pre-insulated 16x2 VarioModular pipe
- > Part No.: V1226 (6 mm Insulation) V1227 (9 mm Insulation)
- > PKU: Roll with 100 m
- > Weight/PKU: 14.0 kg (6 m m Insulation) 14.9 kg (9 m m Insulation)
- > Insulation: Polyethylene soft foam
- > Fire resistance as per EN 14313: CL-s1,d0

- > Retaining clamp ø35
- > Part No.: V2802
- > PKU: 50 pcs.
- > Weight/PKU: 1 kg
- > for affixing the pre-insulated VarioModular pipes 16x2



- > Retaining clamp ø35
- > Part No.: V2803
- > PKU: 25 pcs.
- > Weight/PKU: 1 kg
- > for affixing the pre-insulated VarioModular pipes 16x2



5.4 Press-fit couplings / press tools

Connection options

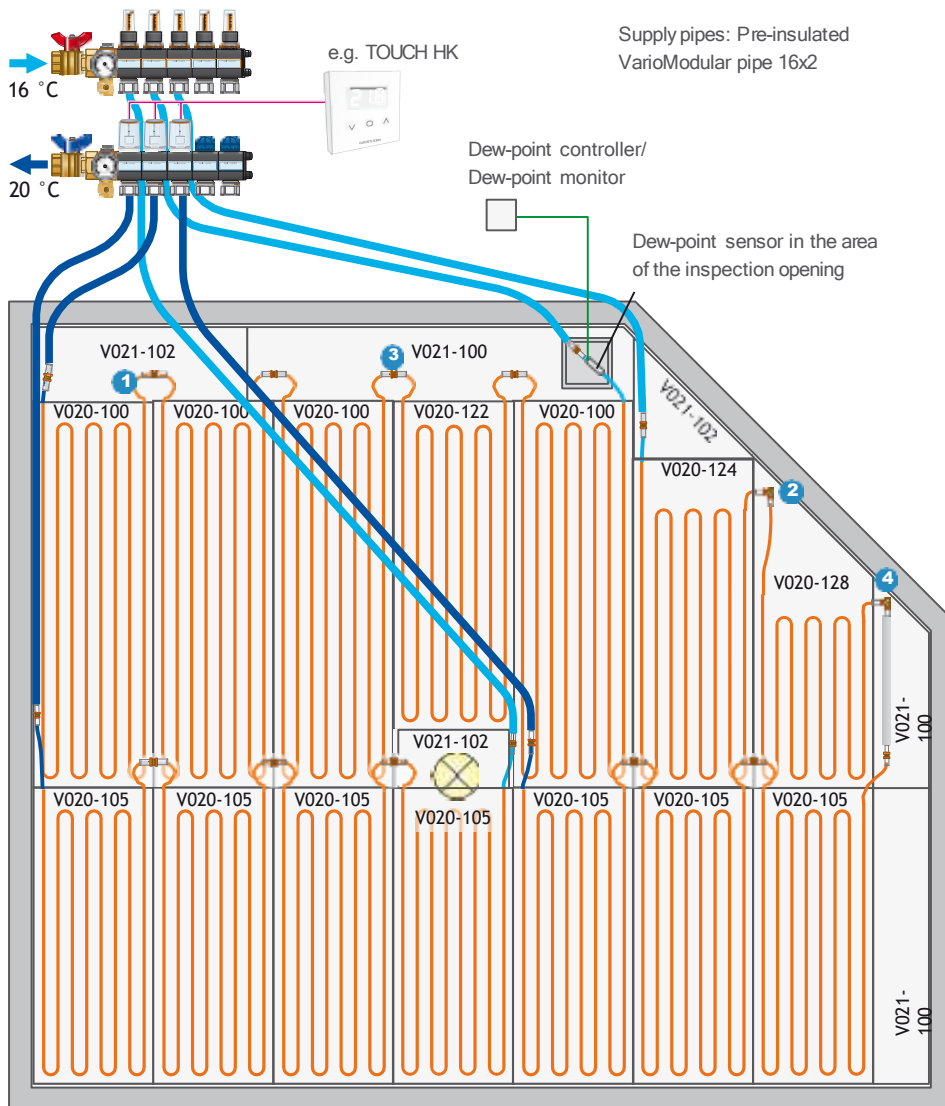

- › Press-fitcoupling 16x11.6 **1**
- › Part No.: Z1610
- › PKU: 1 pce.
- › Weight/PKU: 45 g
- › Press contour: TH11.6 & TH16



- › Press-fit elbow 90° 11.6x11.6
- › Part No.: Z1630
- › PKU: 1 pce.
- › Weight/PKU: 45 g
- › Press contour: TH11.6



- › Press-fitcoupling 11.6x11.6 **3**
- › Part No.: Z1600
- › PKU: 1 pce.
- › Weight/PKU: 30 g
- › Press contour: TH11.6

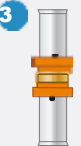

- › Press-fitelbow 90° 16x11.6
- › Part No.: Z1620
- › PKU: 1 pce.
- › Weight/PKU: 45 g
- › Press contour: TH11.6 / TH16

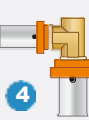

Maximum cooling/heating surface
per cooling/heating circuit

6.25 m²

(e.g. 5 x V020-100)

Observe pump dimensioning!

Pressure loss examples (ti = 20 °C)

Flow/Return	6.25 m ² / circuit	5.0 m ² / circuit
⚡ 35/28 °C	1.3 mWC	0.8 mWC
⚡ 35/30 °C	2.7 mWC	1.6 mWC

Pressure loss examples (ti = 26 °C)

* 16/20 °C	3.2 mWC	1.7 mWC
------------	---------	---------

- › Calibration and chamfering tool
- › Part No.: W042
- › PKU: 1 pce.
- › Weight/PKU: 140 g
- › For calibrating and chamfering the Variotherm pipes

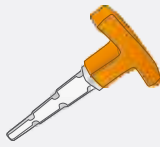

- › Pipe cutting pliers
- › Part No.: W037
- › PKU: 1 pce.
- › Weight/PKU: 230 g
- › For trimming the Variotherm pipes
- › Replacement blade: W0371



- › AkkuPress Mini
- › Part No.: W019
- › PKU: 1 pce.
- › Weight/PKU: 9.9 kg
- › Incl. sheet steel box, press-fitting jaws TH16 Mini & TH11.6 Mini, battery charger, 2 batteries



- › Mini press-fitting jaw TH11.6
- › Part No.: W031
- › PKU: 1 pce.
- › Weight/PKU: 1,5 kg



- › Mini press-fitting jaw TH16
- › Part No.: W032
- › PKU: 1 pce.
- › Weight/PKU: 1.6 kg



- › EcoPress
- › Part No.: W015
- › PKU: 1 pce.
- › Weight/PKU: 9.7 kg
- › Incl. sheet steel box, press-fitting jaws TH16 & TH11.6

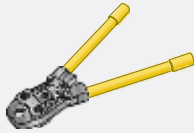

- › Press-fitting jaw TH11.6
- › Part No.: W025
- › PKU: 1 pce.
- › Weight/PKU: 2.0 kg



- › Press-fitting jaw TH16
- › Part No.: W024
- › PKU: 1 pce.
- › Weight/PKU: 2.1 kg



- › Cold shrinking tape
- › Part No.: Z1699
- › PKU: 1 pce. | Carton with 20 pcs.
- › Weight/PKU: 990 g
- › Roll: 50 m m × 15 m
- › 1 roll is sufficient for approx. 35 press-fit coupling connections (with a 50 % overlap)

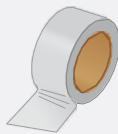

Pipe connection / pressing

Once the panels and the heating/cooling manifolds are installed, the panels are connected to the desired circuits. The pre-insulated VarioModular pipe 16x2 is used as the supply pipe. A lasting, tight connection is only guaranteed if original Variotherm system components are used:

- › VarioModular pipes
- › Variotherm calibration and chamfering tools
- › Variotherm press-fit couplings and Variotherm pressing tools

The press-fitting pliers and drive unit must be checked at least once a year for correct operation by REMS or an authorised REMS customer service workshop.

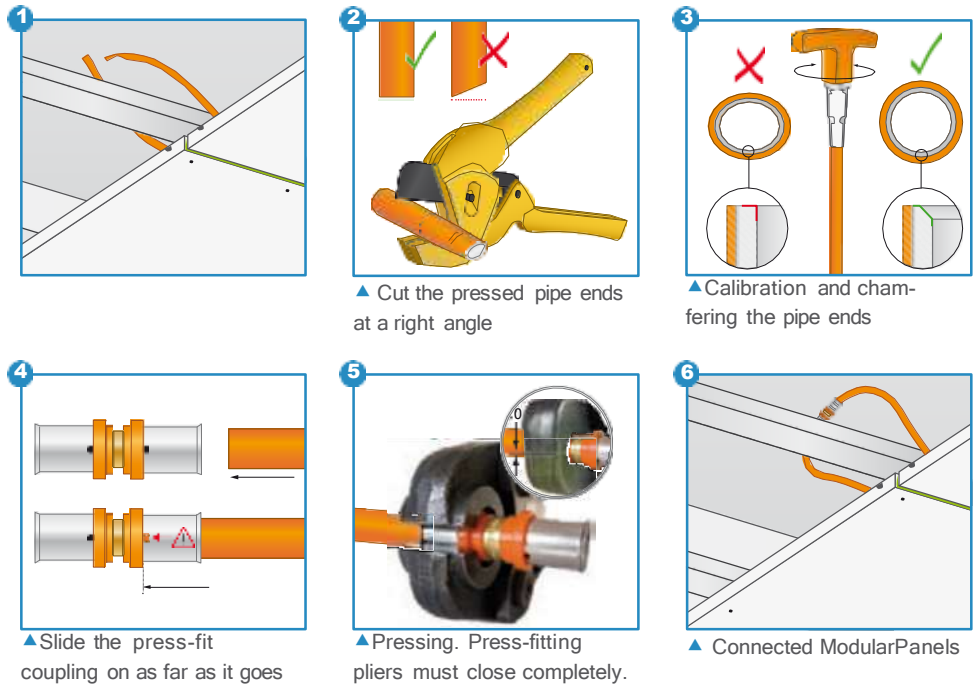

Corrosion prevention measures/ dew-point monitoring

The connecting elements are to be protected (after the pressure test) in accordance with EN 1264 and compliance with ÖN H 5155 (e.g. with Z1699 cold shrink tape). This measure is also a prerequisite for effective dew-point monitoring in the case of cooling (see also Chapter 5.5)

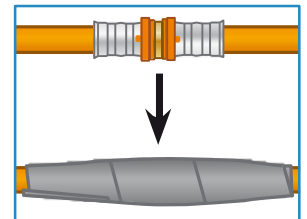

5.5 Dew-point monitor (on-site)

The dew-point sensor is fitted to the part of the pipe that is expected to dew first. This is normally the case on the flow inlet.

Care must be taken that there is a good thermal transition between the pipe and the sensor (use heat-conducting paste) and that there is a stream of ambient around area of the dew-point sensor. For this reason an ambient air connection must be created in the area of the dew-point sensor in the case of closed ceilings.

The supply pipes must be sufficiently fixed.

For further information on the dew point, see also Chapter 8.3.

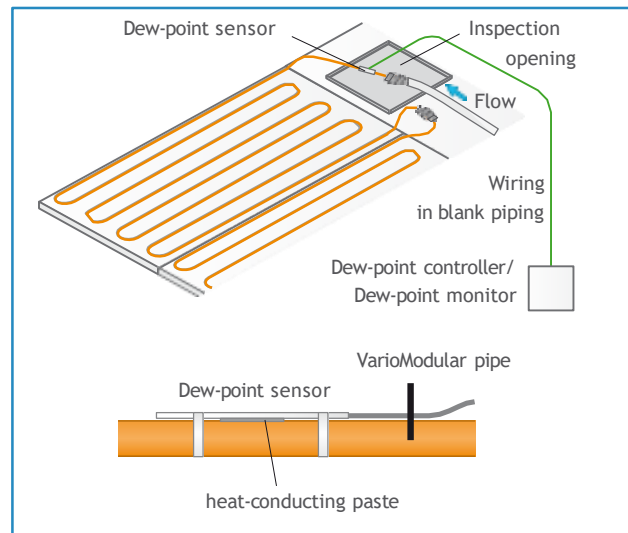

▲ Example Dew-point monitor (cooling)

5.6 VarioManifold

Advantages

- > Plastic manifold with internal air chambers for thermal insulation
- > Flexible conversion to thermostat operation
- > Pre-settable flow indicator in the flow (10-160 l/h) according to EN 1264-4, viewing glass can be cleaned
- > Optimised for **low-temperature** surface heating/cooling
- > Detachable 3-way ball valves on the flow and return bars
- > Venting option, flushing option via rotatable fill and drain cocks
- > Modular construction
- > Absolutely oxygen-tight
- > Designation labels
- > All parts self-sealing, manifold pressure-tested
- > Variable distance between flow and return bars

Pressure test

Once all circuits have been connected to the heating/cooling manifold, the system can be filled downstream of the manifold and pressurised. The pipes must be kept under water pressure prior to completion work (screeding, filling, painting, wallpapering, tiling), so that any damage becomes immediately visible. (Please see Chapter 9.1 for the protocol Leak-tightness test).

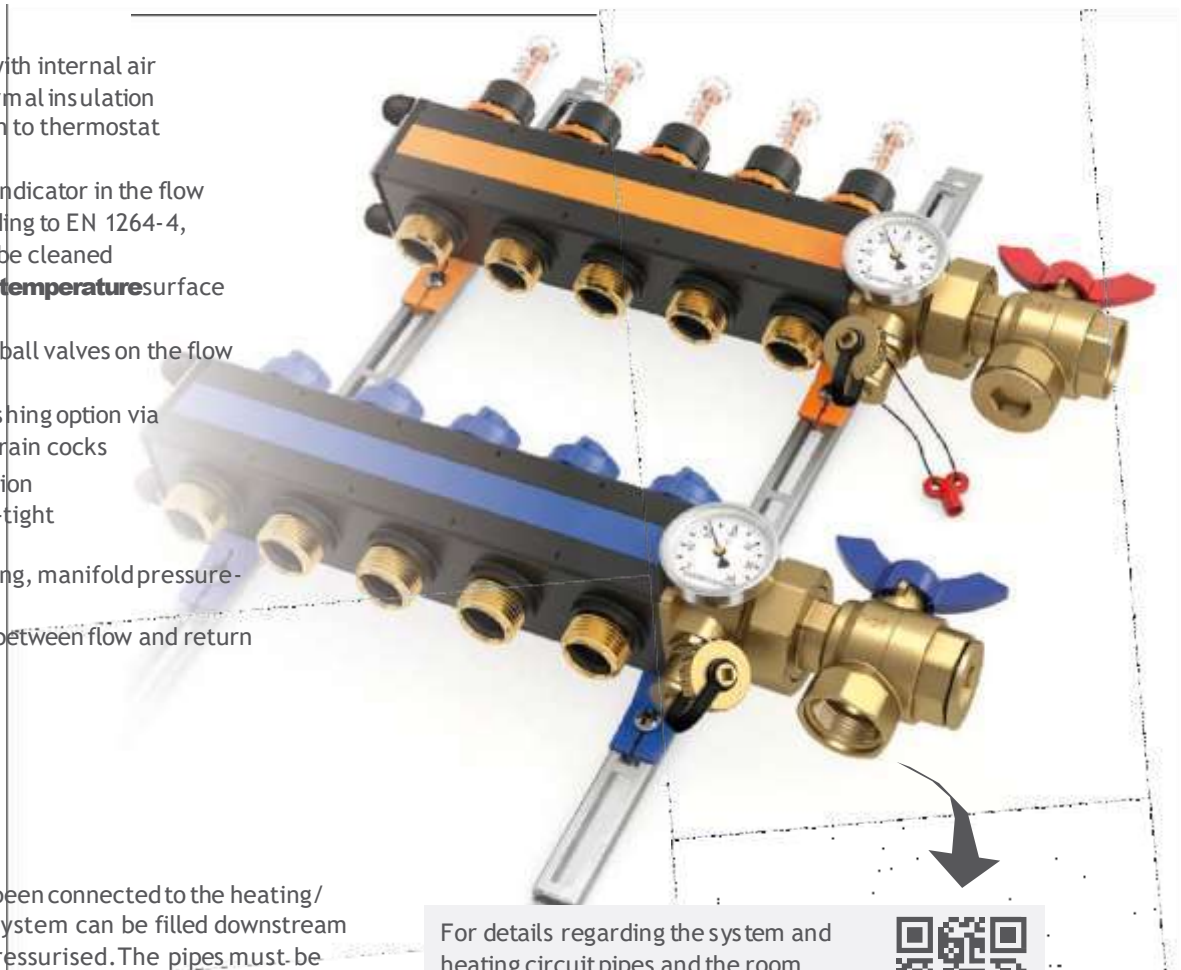

For details regarding the system and heating circuit pipes and the room temperature control please refer to the "DISTRIBUTION and CONTROL" planning and installation instructions



PDF

6 FINISHED SURFACE

6.1 Filling

After installation, the ModularPanels and ModularExpansionPanels are filled with FERMACELL Joint Filler or Fine Surface Filler (or equivalent products). However, before this the joint adhesive that has already hardened must be completely scraped off (depending on the room temperature, the joint adhesive has hardened after approx. 18 to 36 hours). Joint adhesive that is still soft smears when you try to remove it.

Caution: Filling may only be carried out after all wet work (wet screed, plastering, etc.) has dried!

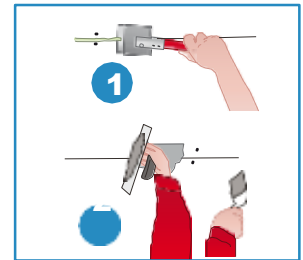

Depending on the required surface quality, the following work must be carried out:

Q1 – Minimum requirement	Q2 – Standard requirement	Q3 – High requirement	Q4 – Highest requirement
<u>Necessary for:</u> - Sealing layers and tiling	<u>Necessary for:</u> - Wallpaper and woodchip (medium or coarse grain) - Matt fillers (dispersion coating, thin plaster)	<u>Necessary for:</u> - Fine-textured wall coverings - Matt, non-textured wall coverings	<u>Necessary for:</u> - Smooth or fine-textured wall coatings - Metal or thin vinyl wallpapers - High-quality finishing technologies
<u>Required work:</u> - Scrapping off excess joint adhesive after hardening - Filling of visible fixings and adhesive joints with Fermacell Joint Filler or Fine Surface Treatment	<u>Required work:</u> - Q1 - Smooth and continuous filling of joints and fixings. No processing marks or filler burrs must remain visible. If necessary, the smoothed surfaces should be sanded	<u>Required work:</u> - Q2 - If necessary broad filling of joints - Full-surface coating and sharp pulling-off of entire surface with Fermacell Fine Surface Treatment or other suitable filling materials. If necessary, the smoothed surfaces should be sanded	<u>Required work:</u> - Q2 - If necessary broad filling of joints - Full-surface coating and smoothing (e.g. with abrasive grid) of entire surface with Fermacell Fine Surface Treatment or other suitable filling materials.
	Settling of joints can't be ruled out, particularly under grazing light	Unevenness visible under grazing light, such as application marks on joints, cannot be excluded, but the unevenness is less than for Q2.	Unevenness at the joints must not be visible.

2. Painting

After filling, commercially available paints, such as latex, dispersion or gloss paints, can be applied to the ModularPanels. Mineral paints such as lime and silicate paints must be approved by the manufacturer for use on gypsum fibreboards. The paint is usually applied in two steps.

3. Load attachment of the ModularCeiling

Small "static" loads can be attached directly to the ModularCeiling according to the following table. **Caution:** Do not damage the VarioModular pipes!

Fixing material - observe the fitting instructions of the dowel manufacturer!	Permissible single loads for individual hanging on ModularPanel (dowel spacing ≥ 300 mm)	Max. permissible area load per m ² ModularPanel (dowel spacing ≥ 300 mm)
	2 kg	6 kg

Heavier suspended elements must only be attached to the substructure and not to the ModularPanel. When installing the substructure these loads must be taken into account (see maximum permissible support span, Chapter 3).

7 ACOUSTICS

Variotherm also offers ModularPanels with sound absorbent properties that significantly reduce the sound levels in living areas and offices. The holes in the gypsum fibre boards channel the impinging sound waves through the panel, where the sound energy is then “broken” and dispersed in the ceiling structure.

Special detail: With the Variotherm ceiling cooling/heating system, the holes of the acoustic panels are not covered by cooling/heating elements and thus remain 100 % active. This allows a tested and guaranteed sound reduction to be achieved.

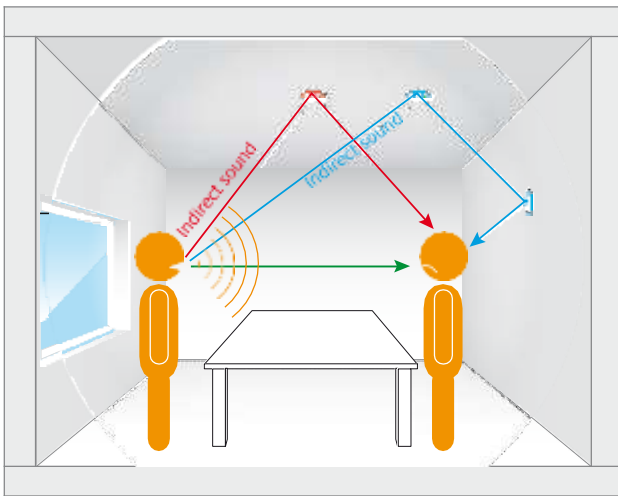

▲ Acoustic reflection

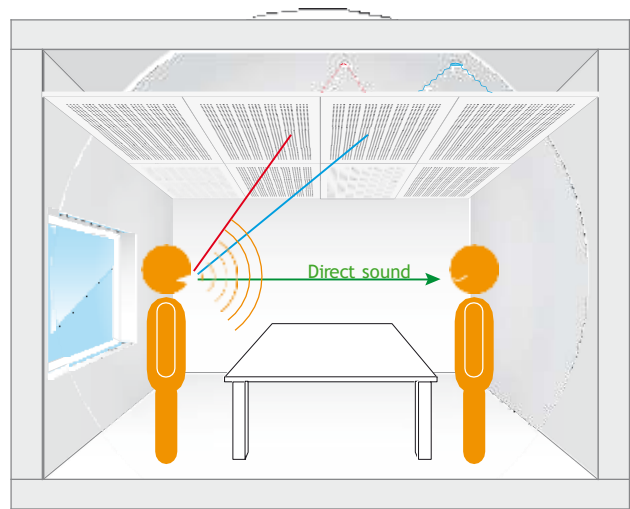

▲ Acoustic reflection with ModularPanel- Acoustic

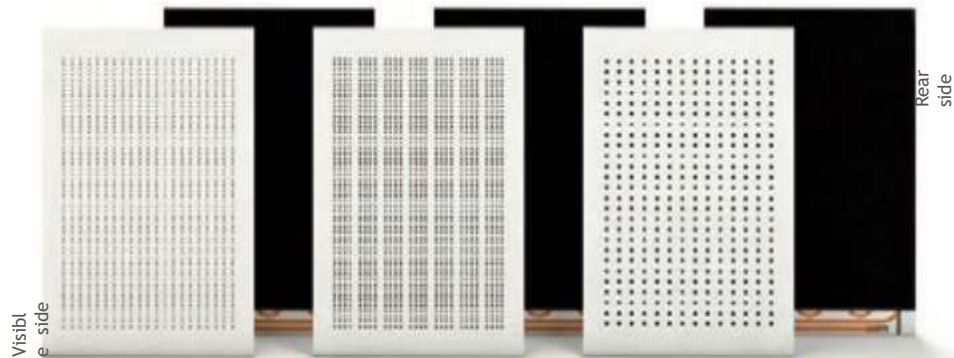

	F06	B08	F12
Part No.	V024-109	V024-104	V024-110
Hole diameter (D):	6 mm	8 mm	12 mm
Hole spacing (R1):	25.0 mm	15.0 mm	37.5 mm
Hole spacing (R2):	16.0 mm	16.0 mm	32.0 mm
Hole percentage:	4.8 %	12.4 %	6.6 %
Hole pattern:	Continuous holes	Block holes	Continuous holes
Panel material:	Gypsum fibreboard which has been tested for their healthy building properties, 18 mm		
Panel size:	1000×625 mm		
Pipe:	VarioModular pipe 11.6x1.5		
Rear side:	Acoustic fleece AV 100, black		
Tested by:	TÜV Rheinland according to DIN EN ISO 3541		

1Measured values of sound absorption available on request!

8 HEATING/COOLING PRACTICE

8.1 Calculation of the heating and cooling load

Variotherm also conducts cooling load calculations (subject to a fee) according to the new VDI 2078 guideline. For calculation purposes, precise information must be provided on the building and the rooms to be cooled (U-values with layer composition, shading, internal loads). This is the precondition for useful, accurate results.

The EN 12831 standard with the respective national annex applies to the heating load calculations for the heated rooms.

Every room is considered individually. For the outside temperature, the locally acquired and standardised outdoor temperature T_{ne} is used.

8.2 Variotherm Dimensioning software

Key values for individual heating/cooling circuits (the amount of water, pressure loss, number of circuits, allocation of the manifolds etc.) can be quickly and easily calculated by inputting the cooling or heating load into the Variotherm dimensioning software. It can be found in our Professional Area at:

www.variotherm.com/professional.

Bezeichnung	Fläche m ²	Kühllast W	Kühllast W/m ²	t _{Raum} °C	t _{sp. Raum} °C
Schlafzimmer	21.70	-1601	-73.76	24.0	23.9
Wohnen, Kochen, Essen	84.50	-3900	-44.99	24.0	24.8
Wirtschaftsraum	13.00	-465	-35.01	24.0	24.0
WC	7.00	-73	-10.50	24.0	24.1
Corridor + Stiege	23.30	-1832	-78.66	24.0	25.4
Lounge + Stiege	22.25	-378	-17.00	24.0	24.3
Küche II (Pantry)	30.50	-966	-31.55	24.0	24.8
Vorraum	10.20	-539	-52.94	24.0	24.5
Küche I (Pantry)	13.10	-411	-31.38	24.0	24.6
Glaszimmer 1	73.50	-613	-8.34	24.0	24.8
Flur + Stiege	12.40	-342	-27.59	24.0	24.6
Glaszimmer 2	28.70	-746	-25.98	24.0	24.8
Gesamt	294.30	-10426	-35.40		

▲ Excerpt of a cooling load calculation (German)

Code	Bezeichnung	U-Wert W/m ² K	q _{ext} m ² /K	R _{ext} m ² K/W	R _{int} m ² K/W	R-Bau m ² K/W
AF01	Außeneinfache	1,100	0,909	0,130	0,040	0,739
A011	Außentür	1,700	0,588	0,130	0,040	0,418
AW01	Außenwand	0,220	4,545	0,130	0,040	4,375

Nr.	Raum	Bezeichnung	t _{ext} °C	A _k m ²	Φ _{ext} W	Φ _{int} W	Φ _v W	Φ _{sonne} W	Φ _{person} W	Φ _{sonn} W	Φ _{ext} W	Φ _{int} W	
													W
	Haus, EG			180,88	5427		3366				9160		3173
00.001.001	Wohnen		20,0	20,10	830	830	531	46	15	1335	0	1335	
00.001.002	Küchen		20,0	20,49	762	762	343	54	19	1106	0	1106	
00.001.003	Wohnen		20,0	24,45	671	671	403	61	11	1463	0	1463	

▲ Excerpt of a cooling load calculation (German)

▲ Variotherm dimensioning software example for heating

▲ Variotherm dimensioning software example for cooling

8.3 Cooling capacity and dew point

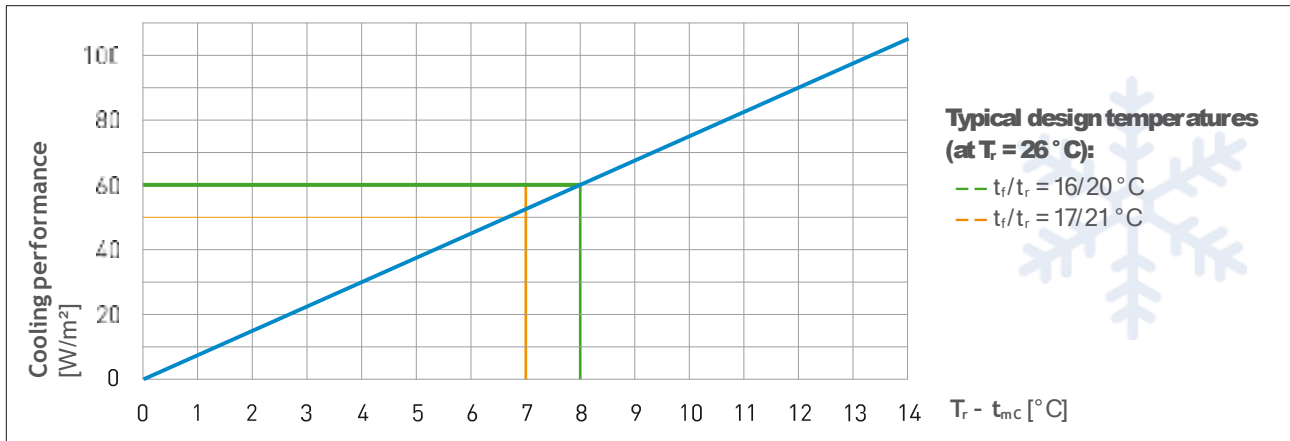

$t_{mc} = \text{Mean cooling water temperature} = \frac{t_r + t_r}{2} \text{ [°C]}$
 $T_r = \text{Room temperature [°C]}$
 $t_r/t_r = \text{Flow temperature / Return temperature [°C]}$

The flow temperature must be selected in such a way or it must be ensured that the surface temperature of the ModularPanel (room-side and cavity) and the pipe never reaches or falls below the dew-point temperature at any point. Whereby the mean surface temperature T_o corresponds approximately to the return flow temperature t_r .

Relative humidity [%rF]	Room temperature T_r [°C]				
	24	25	26	27	28
80 %	20.3	21.3	22.3	23.3	24.2
70 %	18.2	19.1	20.1	21.1	22.0
60 %	15.8	16.7	17.6	18.6	19.5
50 %	12.9	13.9	14.8	15.7	16.6
40 %	9.6	10.5	11.4	12.2	13.1

Dew-point temperature [°C]

Condensation can form on the pipes and surfaces if the flow temperature selected is too low. Control measures must be taken to prevent this (e.g. dew-point monitor).

8.4 Heat emission

Table valid for room heights of 2.5-3.5 m.

For reasons of comfort do not exceed $t_{mH} = 35\text{ °C}$!



t_r/t_r [°C]	t_{mH} [°C]	Heat output [W/m²] at room temperature T_r					T_o [°C] (at $T_r = 20\text{ °C}$)
		$T_r = 15\text{ °C}$	$T_r = 18\text{ °C}$	$T_r = 20\text{ °C}$	$T_r = 22\text{ °C}$	$T_r = 24\text{ °C}$	
30/20	25.0	55	39	27	15	-	27
30/25	27.5	68	54	41	28	15	28
35/25	30.0	82	67	55	42	28	29
35/28	31.5	90	75	62	49	36	30
35/30	32.5	96	81	68	55	42	31
37.5/32.5	35.0	110	95	82	69	55	32
40/30	35.0	110	95	82	69	55	32

$t_{mH} = \text{mean hot water temperature} = \frac{t_r + t_r}{2} \text{ [°C]}$
 $T_r = \text{room temperature [°C]}$
 $T_o = \text{mean surface temperature [°C]}$
 $t_r/t_r = \text{flow temperature / return temperature [°C]}$

8.5 Pressure loss

Example: The pressure loss of a 6.25 m² Modular ceiling cooling (5 pcs. V020-100 at 1 cooling circuit) is to be calculated. The desired flow/return temperature is 16/20 °C resulting in a cooling output of 60 W/m² at a room temperature of 26 °C.

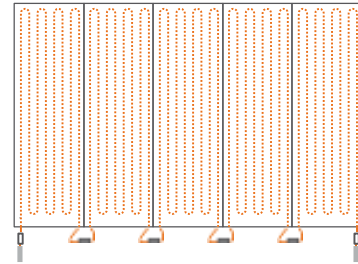

Calculation of the flow rate ω from the pressure loss diagram:

$$Q = 375 \text{ W (60 W/m}^2 \times 6.25 \text{ m}^2)$$

$$\Delta T = 4 \text{ K (20 K - 16 K)}$$

$$c = 1.163 \text{ Wh/kgK (Specific heat capacity of water)}$$

$$m = Q \div c \div \Delta T$$

$$= 375 \text{ W} \div 1.163 \text{ Wh/kgK} \div 4 \text{ K} = 80.6 \text{ kg/h (l/h)}$$

80.6 l/h results, according to the diagram, in:

$$\text{Flow rate } \omega = 0.4 \text{ m/s}$$

$$\text{Pressure loss (Variotherm pipe 11.6x1,5)} = 340 \text{ Pa/m}$$

$$\text{Pressure loss (Variotherm pipe 16x2)} = 60 \text{ Pa/m}$$

Pipe length for 6.25 m² cooling surface = 81 m

(1 pce. V020-100 = 16.2 m pipe, see table on page 16/17)

$$Q = m \times c \times \Delta T$$

Maximum flow rate per cooling/heating circuit of the VarioManifold:
160 l/h

Press-fit coupling	Coefficient of resistance ζ (Zeta)
11.6 x 11.6	7.2
16 x 11.6	6.9

• **Δp for 6,25 m² ModulWand:** 340 Pa/m x 81 m = **27540 Pa**

• **Δp for 15m pre-insulated VarioModular pipe 16x2:** 60 Pa/m x 15 m = **900 Pa**

• **Δp for 4 pcs. press-fit couplings 11.6x11.6:** $\zeta \times \rho/2 \times \omega^2 = 7.2 \times 500 \text{ kg/m}^3 \times (0.4 \text{ m/s})^2 = 576 \text{ Pa} \times 4 \text{ pcs.} = \text{2304 Pa}$

• **Δp for 2 pcs. press-fit couplings 16x11.6:** $\zeta \times \rho/2 \times \omega^2 = 6.9 \times 500 \text{ kg/m}^3 \times (0.4 \text{ m/s})^2 = 552 \text{ Pa} \times 2 \text{ pcs.} = \text{1104 Pa}$

$$\Delta p_{\text{Total}} = 27540 \text{ Pa} + 900 \text{ Pa} + 2304 \text{ Pa} + 1104 \text{ Pa} = \text{31848 Pa} = \text{3.18 mWC}$$

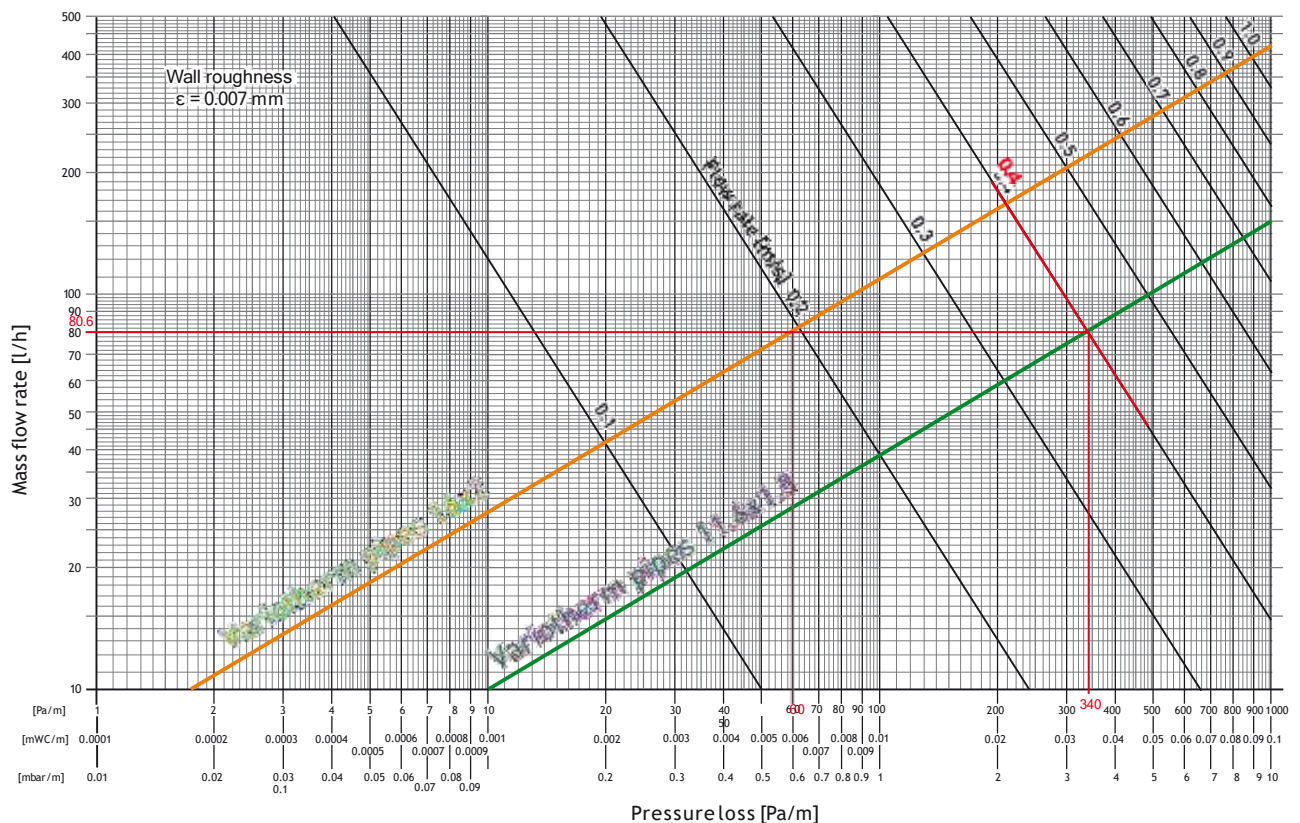

8.6 Arrangement of the cooling/heating surfaces

Ceilings and roof slopes are ideally suited as cooling and heating surfaces, as the radiation surfaces are not obstructed by furnishings.

Experience shows that the comfort effect is perceived up to 3.5 m away from the thermally active ceiling. As the radiation effect on the body declines in proportion to the square of the distance, it is advantageous to suspend the ceiling in higher rooms, or alternatively to combine it with wall heating/wall cooling or floor heating.

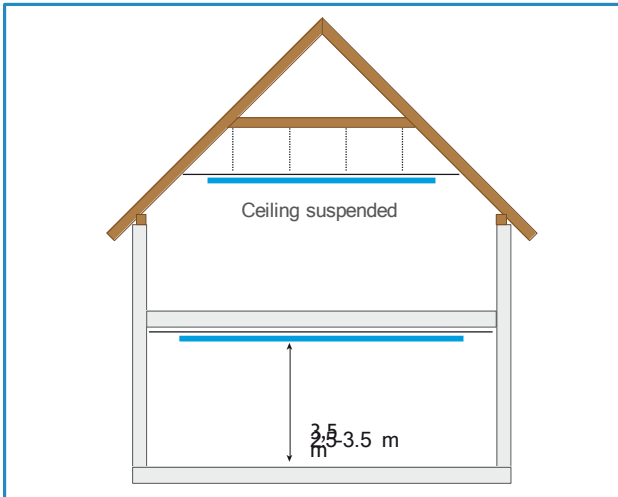

Guide values for dimensioning¹ the ModularCeiling:

50 to 60 % of the room floor area	70 to 80 % of the room floor area
+ Heating o Slight cooling	+ Cooling + Heating + Energy saving due to lower flow temperature
Example, 20 m ² area:	Example, 20 m ² area:
<p>11.9 m² (= 59.5%)</p>	<p>15.0 m² (= 75%)</p>

If the ceiling is dimensioned for heating, experience has shown that it still achieves a good cooling effect (slight cooling) if this surface is used for cooling in summer. Conversely, the flow temperature can be reduced in winter when heating if the ceiling area is dimensioned for cooling. This saves energy!

¹ Observe the heating/cooling load calculation for precise dimensioning of the area required!

ModularCeiling as a "ceiling sail"

Pay attention to the VarioModular pipes when fastening the ModularPanels in the edge areas (deviation from fastening area)!



▲ Example of a "ceiling sail"

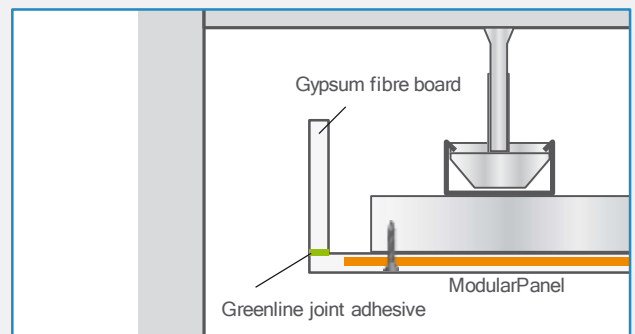

▲ Example: Execution of the edges



▲ Example of a "ceiling sail" with indirect lighting

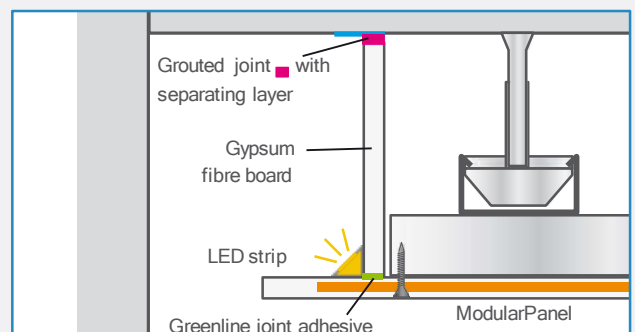

▲ Example: Execution of the edges with LED strip

9 PROTOCOLS

9.1 Leak-tightness test (in accordance with EN 1264-4)

After installation and before completion work (screed, plastering, painting, wallpapering), the circuits of the Variotherm Modular Ceiling must be checked for leak-tightness by means of a water pressure test. The test pressure should be min. 4 bar and max. 6 bar. Due to the initial pipe expansion, it may be necessary to re-pump the test pressure. If there is a risk of freezing, appropriate measures should be taken, e. g. use of antifreeze and controlling the building's temperature.

Construction project: _____

Building owner/occupant: _____

Client:

Heating installer: _____

Architect: _____

Others: _____

- › Installation of Modular Panels finished on: _____
- › Installation of pipe connections finished on: _____
- › Pressure test started on: _____ with test pressure ____ bar
- › Pressure test finished on: _____ with test pressure ____ bar
- › Start of completion work (screeding, plastering, painting, wallpapering etc.) on: _____
- › System pressure during the completion work was ____ bar
- › The system water was treated (e.g. per ÖNORM H 5195-1, VDI 2035) Yes No
- › Antifreeze was added to the system water Yes No
- › The system was checked for leak-tightness: _____ and approved

Approval:

Building owner/Occupant/Client

Construction management/Architect

Heating installer

ENJOY THE COMFORT & SAVE ENERGY

That's why our customers love us:
Heating and cooling optimised for COMFORT in all rooms!
Fast and friendly service, ANSWERS backed up with expertise!
Always in tune with the latest technology, INNOVATION guaranteed!
Everything CLEAR and SIMPLE, in writing of course!
PROFESSIONALISM at all times, from the first contact to the reference list!

VARIOTHERMS SINCE 1979

Variotherm is an Austrian model plant with hundreds of partners in Austria, Europe and around the world.



VBOOK4_EN | 12/2022



Your Partner

VARIOTHERM კლიმაკომფორტ

თბილისი / დიდი დილომი
დემეტრე თევდადეშელი N-26
მობ: 00995-595121265
ვებ: www.dimacomfort.co.uk
მეილ: nfo@dimacomfort.co.uk

All rights pertaining to distribution and translation, in whole or in part, including film, radio, television, video recording, Internet, photocopying and reprinting, are reserved. Subject to mistakes and printing errors. Misprints and errors excepted.